



() Preliminary Specification
(V) Final Specification

Module	24" Color TFT LCD
Model Name	M240HW02 V5

Customer	Date
_____	_____
Approved by	
_____	_____

Approved by	Date
<u>Winnie Chang</u>	<u>2010/05/30</u>
Prepared by	
<u>Tony Kao</u>	<u>2010/05/30</u>

Note: This Specification is subject to change without notice.

Desktop Display Business Group /
AU Optronics corporation

Contents

1.0 Handling Precautions	4
2.0 General Description	5
2.1 Display Characteristics	5
2.2 Optical Characteristics	6
3.0 Functional Block Diagram	10
4.0 Absolute Maximum Ratings	11
4.1 TFT LCD Module	11
4.2 Backlight Unit	11
4.3 Absolute Ratings of Environment	11
5.0 Electrical characteristics	12
5.1 TFT LCD Module	12
5.1.1 Power Specification	12
5.1.2 Signal Electrical Characteristics	13
5.2 Backlight Unit	15
6.0 Signal Characteristic	16
6.1 Pixel Format Image	16
6.2 The input data format	17
6.3 Signal Description	18
6.4 Timing Characteristics	21
6.5 Timing diagram	22
6.6 Power ON/OFF Sequence	23
7.0 Connector & Pin Assignment	24
7.1 TFT LCD Module	24
7.1.1 Pin Assignment	24
7.2 Connector on Backlight Unit	25
7.2.1 Pin assignment	26
8.0 Reliability Test	27
9.0 Shipping Label	28
10.0 Mechanical Characteristics	29
11.0 Packing Specification	31

Record of Revision

Version and Date	Page	Old description	New Description	Remark
0.1 2010/11/29		First Version		
0.2 2011/03/24	6	Response time Raising time: 7 ms Falling time: 7 ms Raising+Falling time: 14ms	Response time Raising time: 7 ms Falling time: 5 ms Raising+Falling time: 12ms	
0.3 2011/4/20	5	2.1 Display Characteristics Power Consumption (VDD line + LED line) 7.5W	2.1 Display Characteristics Power Consumption (VDD line + LED line) 8W	
	10	I/F PCB Interface: 185132 15021 Mating Type: 12507HS 15L	I/F PCB Interface: 12507WR H15L Mating Type: 12507HS H15L	
	12	5.1.1 Power Specification DD Typ. 1.5A PDD Typ. 7.5W IRush Max. TBD	5.1.1 Power Specification IDD Typ. 1.6A PDD Typ. 8W IRush Max. 3A	
	13	5.1.2 Signal Electrical Characteristics Input signals shall be low or Hi Z state when VDD is off. Please refer to specifications of SN75LVDS82DGG (Texas Instruments) in detail.	5.1.2 Signal Electrical Characteristics Input signals shall be low or Hi Z state when VDD is off.	
	18	6.3 Signal Description The module using one LVDS receiver SN75LVDS82(Texas Instruments). LVDS is a differential signal technology for LCD interface and high speed data transfer device. LVDS transmitters shall be SN75LVDS83(negative edge sampling). The first/third LVDS port(RxOxx) transmits odd pixels while the second/fourth LVDS port(RxExx) transmits even pixels.	6.3 Signal Description The module using 51pin 4port LVDS interface. LVDS is a differential signal technology for LCD interface and high speed data transfer device. The first/third LVDS port(RxOxx) transmits odd pixels while the second/fourth LVDS port(RxExx) transmits even pixels.	
	21	6.4 Timing Characteristics Basically, interface timing described here is not actual input timing of LCD module but close to output timing of SN75LVDS82DGG (Texas Instruments) or equivalent.	6.4 Timing Characteristics The input timing characteristics are shown as the following table	
	24	VDD Connector: Manufacturer: P TWO or compatible Type Part Number: 185132 15021 Mating Housing Part Number: Yeon Ho 12507HS 15L	VDD Connector: Manufacturer: YEONHO or compatible Type Part Number: 12507WR H15L Mating Housing Part Number: YEONHO 12507HS H15L	
1.0 2011/5/30	6	Central Luminance 200nits	Central Luminance 280nits	
	24	7.1 TFT LCD Module LVDS connector: JAE or compatible	7.1 TFT LCD Module LVDS connector: JAE	
	24	7.1 TFT LCD Module VDD connector: YEONHO or compatible	7.1 TFT LCD Module VDD connector: YEONHO	
	All		Final the Spec.	

1.0 Handling Precautions

- 1) Since front polarizer is easily damaged, pay attention not to scratch it.
- 2) Be sure to turn off power supply when inserting or disconnecting from input connector.
- 3) Wipe off water drop immediately. Long contact with water may cause discoloration or spots.
- 4) When the panel surface is soiled, wipe it with absorbent cotton or other soft cloth.
- 5) Since the panel is made of glass, it may break or crack if dropped or bumped on hard surface.
- 6) Since CMOS LSI is used in this module, take care of static electricity and insure human earth when handling.
- 7) Do not open or modify the Module Assembly.
- 8) Do not press the reflector sheet at the back of the module to any directions.
- 9) In case if a Module has to be put back into the packing container slot after once it was taken out from the container, do not press the center of the LED lightbar edge. Instead, press at the far ends of the LED light bar edge softly. Otherwise the TFT Module may be damaged.
- 10) At the insertion or removal of the Signal Interface Connector, be sure not to rotate nor tilt the Interface Connector of the TFT Module.
- 11) After installation of the TFT Module into an enclosure, do not twist nor bend the TFT Module even momentary. At designing the enclosure, it should be taken into consideration that no bending/twisting forces are applied to the TFT Module from outside. Otherwise the TFT Module may be damaged.
- 12) Small amount of materials having no flammability grade is used in the LCD module. The LCD module should be supplied by power complied with requirements of Limited Power Source (IEC60950 or UL1950), or be applied exemption.
- 13) Please avoid touching COF position while you are doing mechanical design
- 14) When storing modules as spares for a long time, the following precaution is necessary:
Store them in a dark place. Do not expose the module to sunlight or fluorescent light. Keep the temperature between 5□ and 35□ at normal humidity.

2.0 General Description

This specification applies to the 24 inch FHD Color a Si TFT LCD Module M240HW01. The display supports the FHD 1920(H) x 1080(V) screen format and 16.7M colors (RGB 6 bits + Hi FRC data). The light source of this TFT LCD module is W LED. All input signals are 4 channel LVDS interface and this module doesn't contain a driver for backlight.

2.1 Display Characteristics

The following items are characteristics summary on the table under 25□ condition:

ITEMS	Unit	SPECIFICATIONS
Screen Diagonal	[mm]	609.7(24.0")
Active Area	[mm]	531.36 (H) x 298.89 (V)
Pixels H x V		1920(x3) x 1080
Pixel Pitch	[um]	276.75 (per one triad) ×276.75
Pixel Arrangement		R.G.B. Vertical Stripe
Display Mode		VA Mode, Normally Black
White Luminance (Center)	[cd/m ²]	350 cd/m ² (Typ.)
Contrast Ratio		5000(Typ.)
Optical Response Time	[msec]	14ms (Typ., on/off)
Nominal Input Voltage VDD	[Volt]	+5.0 V (Typ)
Power Consumption (VDD line + LED line)	[Watt]	BL 32.64W PCBA 8W
Weight	[Grams]	2755 (Typ)
Physical Size	[mm]	556.0(H)x323.2(V)x14.55(D)
Electrical Interface		Quad channel LVDS
Support Color		16.7M colors (RGB 6-bit + Hi_FRC)
Surface Treatment		Anti-Glare, 3H
Temperature Range		
Operating	[°C]	0 to +50
Storage (Shipping)	[°C]	-20 to +60
RoHS Compliance		RoHS Compliance
TCO Compliance		TCO 5.1 Compliance

2.2 Optical Characteristics

The optical characteristics are measured under stable conditions at 25□:

Item	Unit	Conditions	Min.	Typ.	Max.	Note
Viewing Angle	[degree]	Horizontal (Right) CR = 10 (Left)	150	178	- -	2
		Vertical (Up) CR = 10 (Down)	150	178	- -	
Contrast ratio		Normal Direction	4000	5000	-	3
Response Time	[msec]	Raising Time (T _{rR})	-	7		4
		Falling Time (T _{rF})	-	5		
		Raising + Falling	-	12		
Color / Chromaticity Coordinates (CIE)		Red x	0.620	0.650	0.680	5
		Red y	0.314	0.344	0.374	
		Green x	0.308	0.338	0.368	
		Green y	0.603	0.633	0.663	
		Blue x	0.130	0.160	0.190	
		Blue y	0.030	0.060	0.090	
Color Coordinates (CIE) White		White x	0.283	0.313	0.343	
		White y	0.299	0.329	0.359	
Central Luminance	[cd/m ²]		280	350	-	6
Luminance Uniformity	[%]		75	80	-	7
Crosstalk (in 60Hz)	[%]				1.5	8
Flicker	dB				-20	9

Note 1: Measurement method

The LCD module should be stabilized at given temperature for 30 minutes to avoid abrupt temperature change during measuring (at surface $35\pm$). In order to stabilize the luminance, the measurement should be executed after lighting Backlight for 30 minutes in a stable, windless and dark room.

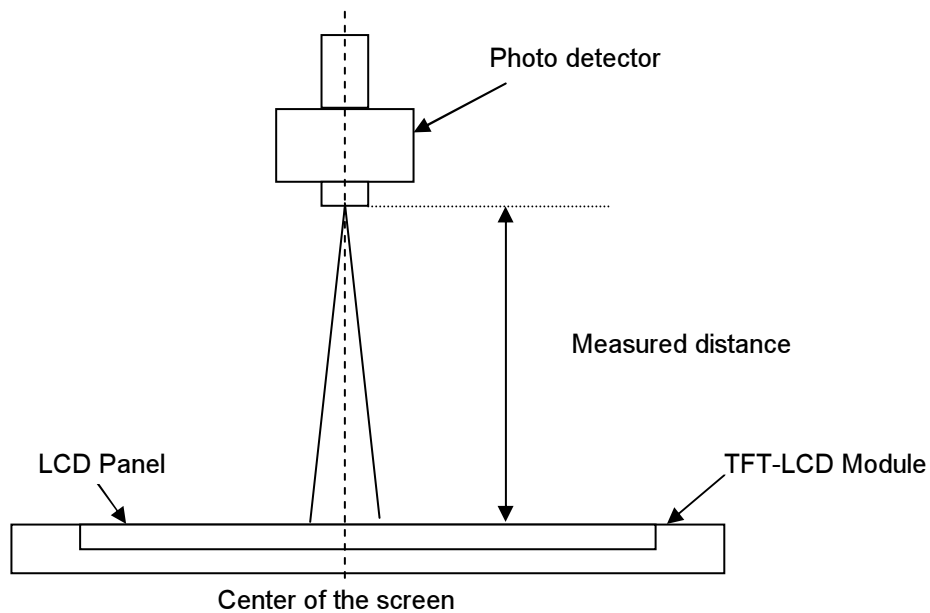

Note 2: Definition of viewing angle measured by ELDIM (EZContrast 88)

Viewing angle is the measurement of contrast ratio ≥ 10 , at the screen center, over a 180° horizontal and 180° vertical range (off normal viewing angles). The 180° viewing angle range is broken down as follows; 90° (θ) horizontal left and right and 90° (ϕ) vertical, high (up) and low (down). The measurement direction is typically perpendicular to the display surface with the screen rotated about its center to develop the desired measurement viewing angle.

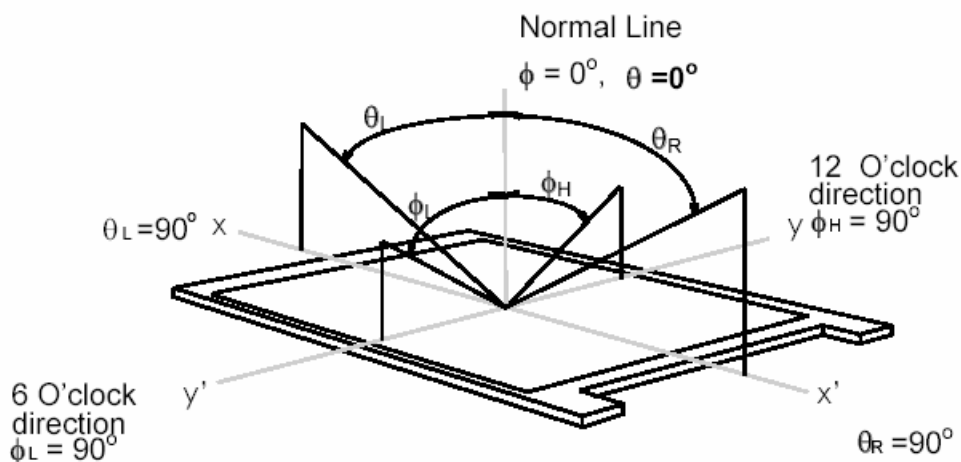

Note 3: Contrast ratio is measured by TOPCON SR 3

Note 4: Definition of Response time measured by Westar TRD 100A

The output signals of photo detector are measured when the input signals are changed from “Full Black” to “Full White” (rising time, T_{rR}), and from “Full White” to “Full Black” (falling time, T_{rF}), respectively. The response time is interval between the 10% and 90% (1 frame at 60 Hz) of amplitudes.

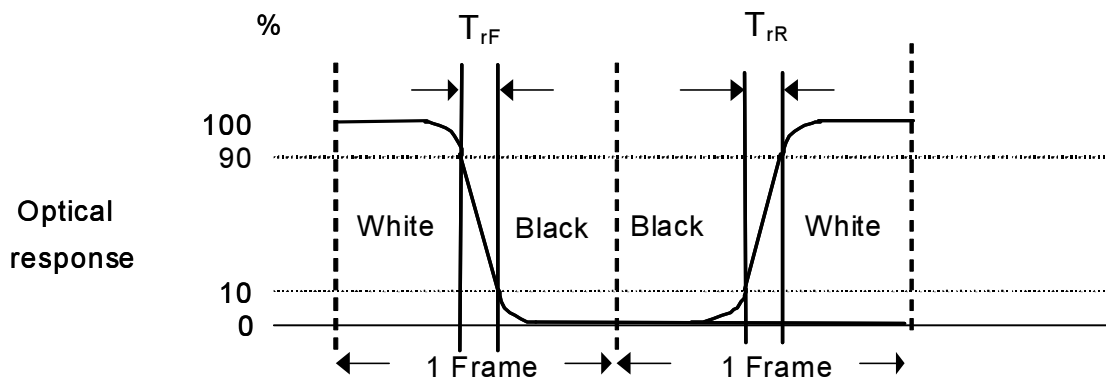

$$T_{rR} + T_{rF} = 14 \text{ msec (typ.)}$$

Note 5: Color chromaticity and coordinates (CIE) is measured by TOPCON SR 3

Note 6: Central luminance is measured by TOPCON SR 3

Note 7: Luminance uniformity of these 9 points is defined as below and measured by TOPCON SR 3

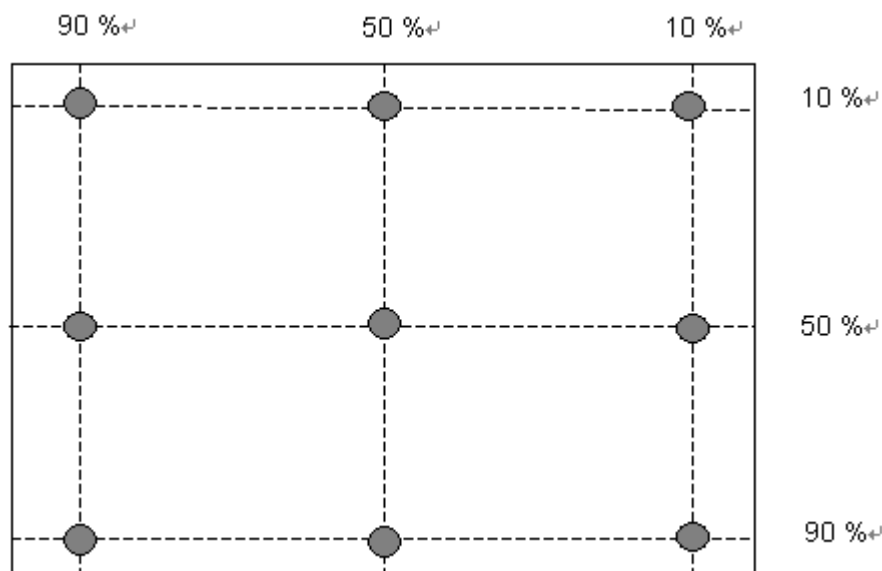

$$\text{Uniformity} = \frac{\text{Minimum Luminance in 9 points (1-9)}}{\text{Maximum Luminance in 9 Points (1-9)}}$$

Note 8: Crosstalk is defined as below and measured by TOPCON SR 3

$$CT = |Y_B - Y_A| / Y_A \times 100 (\%)$$

Where

Y_A = Luminance of measured location without gray level 0 pattern (cd/m²)

Y_B = Luminance of measured location with gray level 0 pattern (cd/m²)

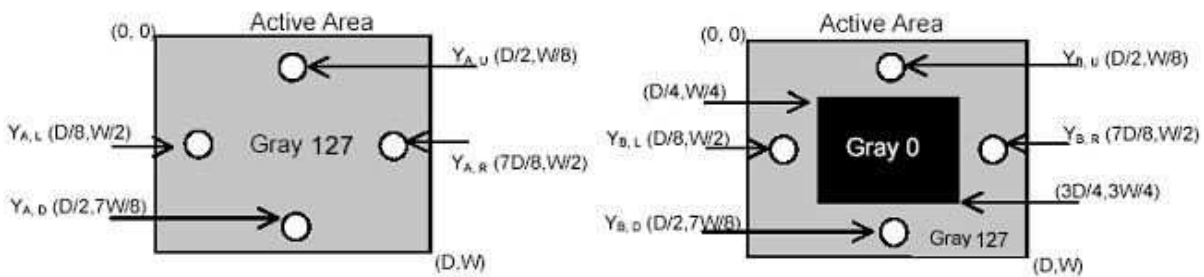

Note 9: Test Pattern: Subchecker Pattern measured by TOPCON SR 3

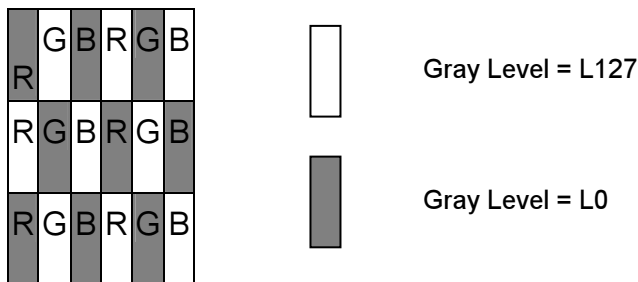

Method: Record dBV & DC value with TRD 100

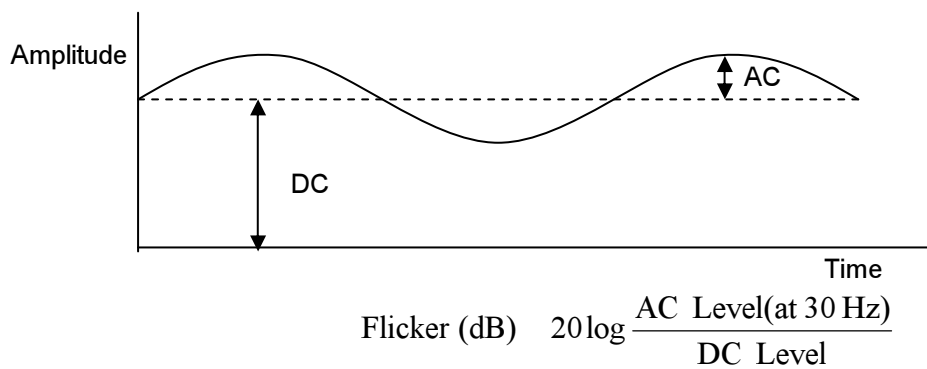

3.0 Functional Block Diagram

The following diagram shows the functional block of the 24.0 inch Color TFT LCD Module:

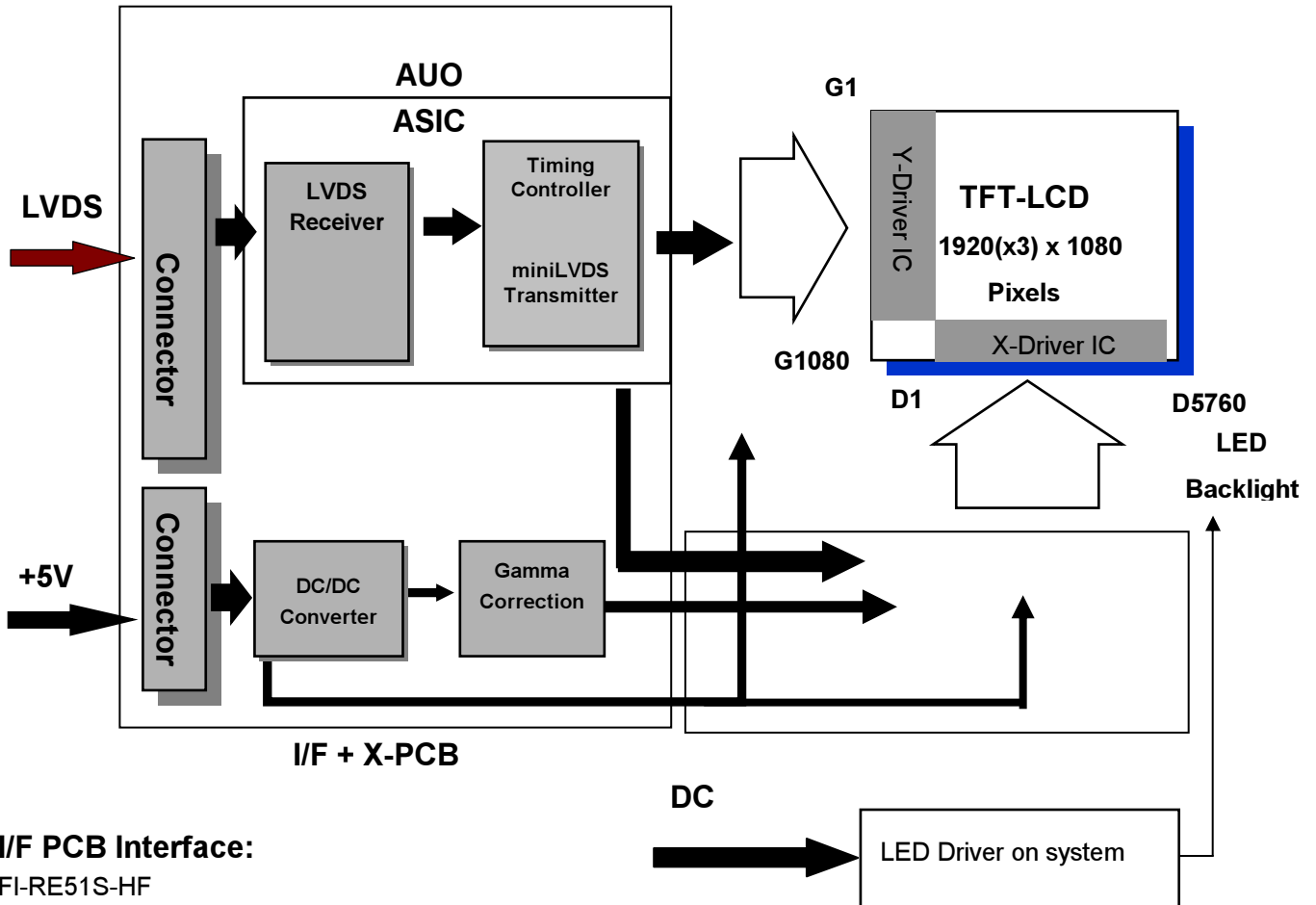

I/F PCB Interface:

FI-RE51S-HF
12507WR-H15L

Mating Type:

FI-RE51HL
12507HS-H15L

4.0 Absolute Maximum Ratings

Absolute maximum ratings of the module are as following:

4.1 TFT LCD Module

Item	Symbol	Min	Max	Unit	Conditions
LCD Drive Voltage	VDD	0	6	[Volt]	Note 1,2
Logic Voltage	2D_3D SW	0	4	[Volt]	

4.2 Backlight Unit

	Symbol	Min	Max	Unit	Conditions
LED Current	ILED	-	63	[mA]	Note 1,2

4.3 Absolute Ratings of Environment

Item	Symbol	Min.	Max.	Unit	Conditions
Operating Temperature	TOP	0	+50	[°C]	Note 3
Glass surface temperature (operation)	TGS	0	+65	[°C]	Note 3, Note 4
Operation Humidity	HOP	5	90	[%RH]	Note 3
Storage Temperature	TST	-20	+60	[°C]	
Storage Humidity	HST	5	90	[%RH]	

Note 1: With in Ta (25□)

Note 2: Permanent damage to the device may occur if exceeding maximum values

Note 3: Temperature and relative humidity range are shown as the below figure.

1. 90% RH Max (Ta ≤ 39°C)
2. Max wet-bulb temperature at 39°C or less. (Ta ≤ 39°C)
3. No condensation

Note 4: Function Judged only

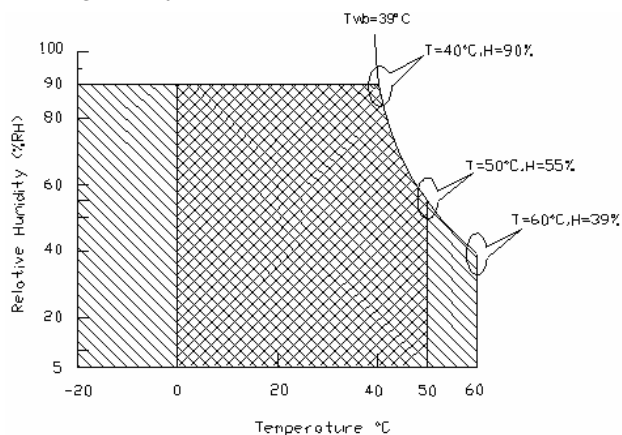

Operating Range



Storage Range

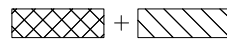

5.0 Electrical characteristics

5.1 TFT LCD Module

5.1.1 Power Specification

Input power specifications are as following:

Symbol	Parameter	Min	Typ	Max	Unit	Conditions
VDD	LCD Drive Voltage	4.5	5.0	5.5	[Volt]	+/-10%
IDD	Input Current	-	1.6	2.5	[A]	VDD= 5.0V, All white Pattern, At 120Hz
PDD	VDD Power	-	8	12.5	[Watt]	VDD= 5.0V, All white Pattern, At 120Hz
IRush	Inrush Current	-	-	3	[A]	Note 1
VDDrp	Allowable Logic/LCD Drive Ripple Voltage	-	-	500	[mV] p-p	VDD= 5.0V, All white Pattern At 120Hz
2D_3D SW	High Level Input Voltage	2.75	-	3.5	[Volt]	
2D_3D SW	Low Level Input Voltage	-	-	0.3	[Volt]	

Note 1: Measurement conditions:

The duration of rising time of power input is 470us.

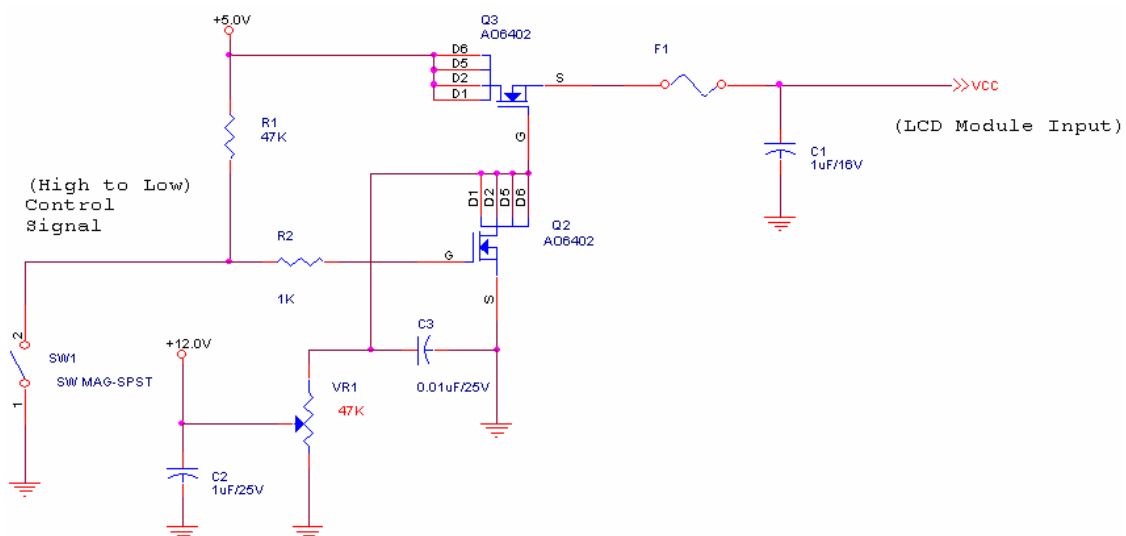

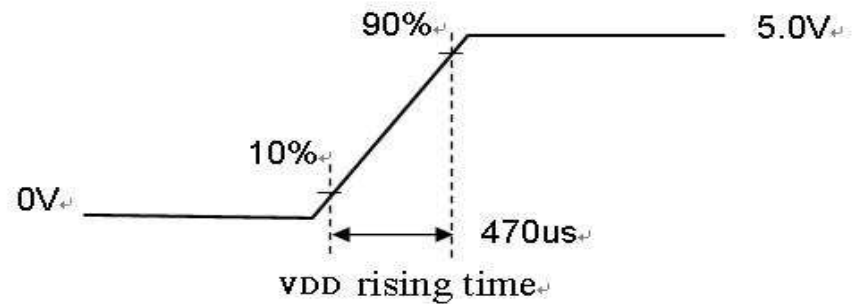

5.1.2 Signal Electrical Characteristics

Input signals shall be low or Hi Z state when VDD is off.

1. DC Characteristics of each signal are as following:

Symbol	Parameter	Min	Typ	Max	Units	Condition
V_{TH}	Differential Input High Threshold	-	+50	+100	[mV]	$V_{CM} = 1.2V$ Note 1
V_{TL}	Differential Input Low Threshold	-100	-50	-	[mV]	$V_{CM} = 1.2V$ Note 1
$ V_{ID} $	Input Differential Voltage	100	-	600	[mV]	Note 1
V_{CM}	Differential Input Common Mode Voltage	+1.0	+1.2	+1.5	[V]	$V_{TH}-V_{TL} = 200MV$ (max) Note 1

Note 1: LVDS Signal Waveform

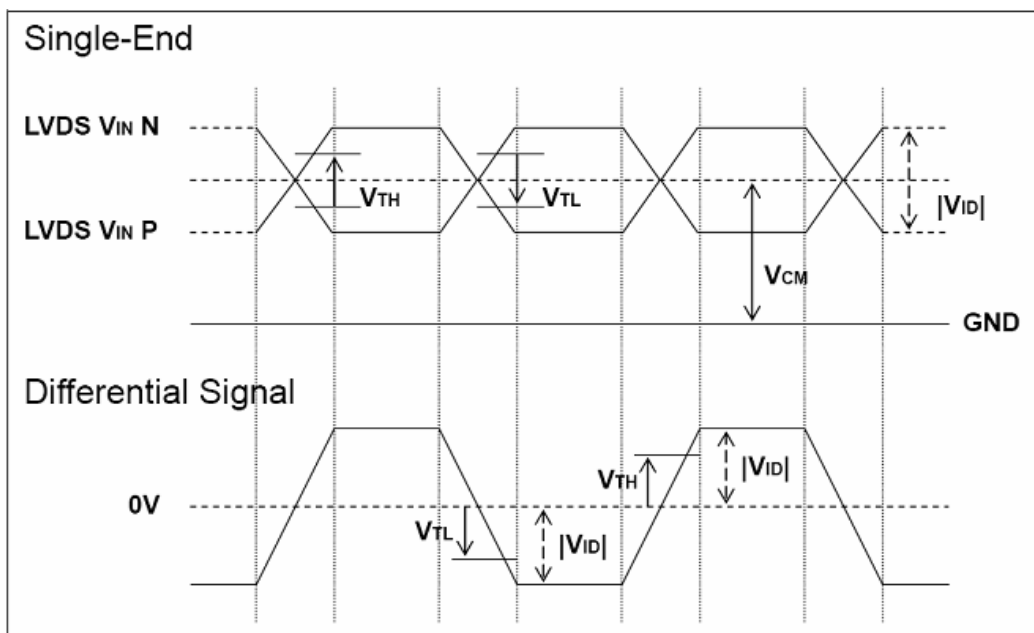

2. AC Characteristics

Description	Symbol	Min	Max	Unit	Note
Maximum deviation of input clock frequency during SSC	F_{DEV}	-	± 3	%	
Maximum modulation frequency of input clock during SSC	F_{MOD}	-	200	KHz	

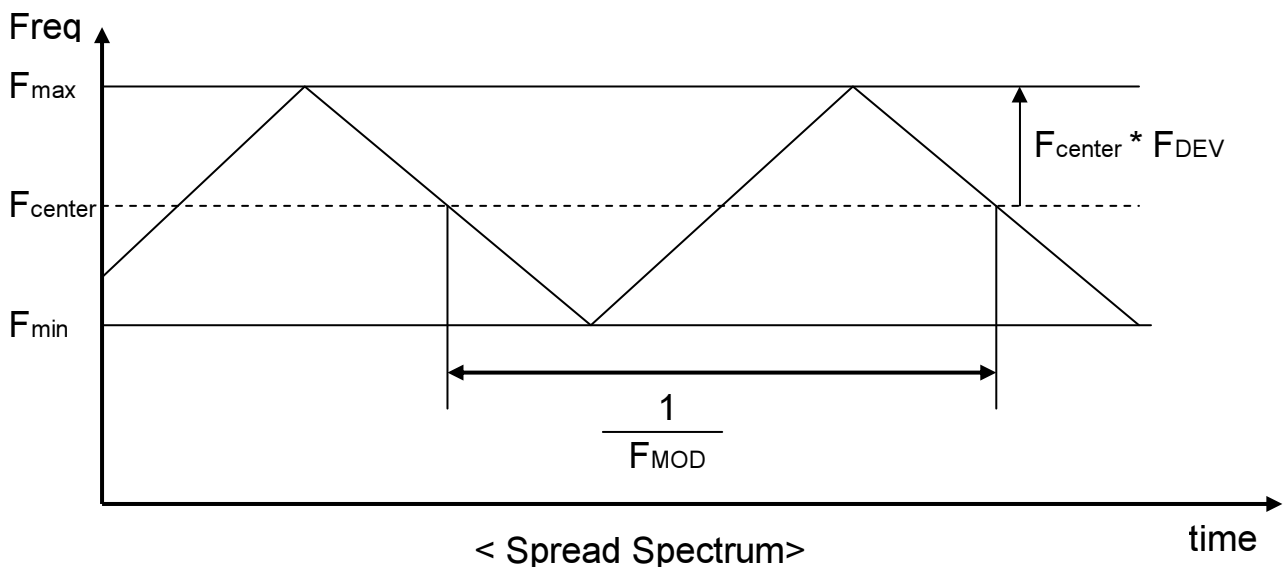

5.2 Backlight Unit

Parameter guideline for LED driving is under stable conditions at 25°C (Room Temperature):

Symbol	Parameter	Min.□	Typ.	Max.	Unit	Note
$I_{R_{LED}}$	LED Operation Current	57	60	63	[mA] Note 1	Operating with fixed driving current
V_{LB}	Light Bar Operation Voltage (for reference)	60	68	72	[Volt] Note 2	
P_{BLU}	BLU Power consumption (for reference)	27.36	32.64	36.3	[Watt]	
LT_{LED}	LED life Time (Typical)	30000		-	[Hour] Note 3	

Note 1 : The specified current is input LED chip 100% duty current.

Note 2 : The value showed in the table is one light bar's operation voltage.

Note 3 : Definition of life time : brightness becomes 50% of its original value. The minimum life time of LED unit is on the condition of $I_{R_{LED}} = 60\text{mA}$ and $25\pm 2^\circ\text{C}$ (Room temperature).

Note 4 : Each LED light bar consists of 80 pcs LED package (4 strings x 20 pcs / string).

6.0 Signal Characteristic

6.1 Pixel Format Image

Following figure shows the relationship of the input signals and LCD pixel format.

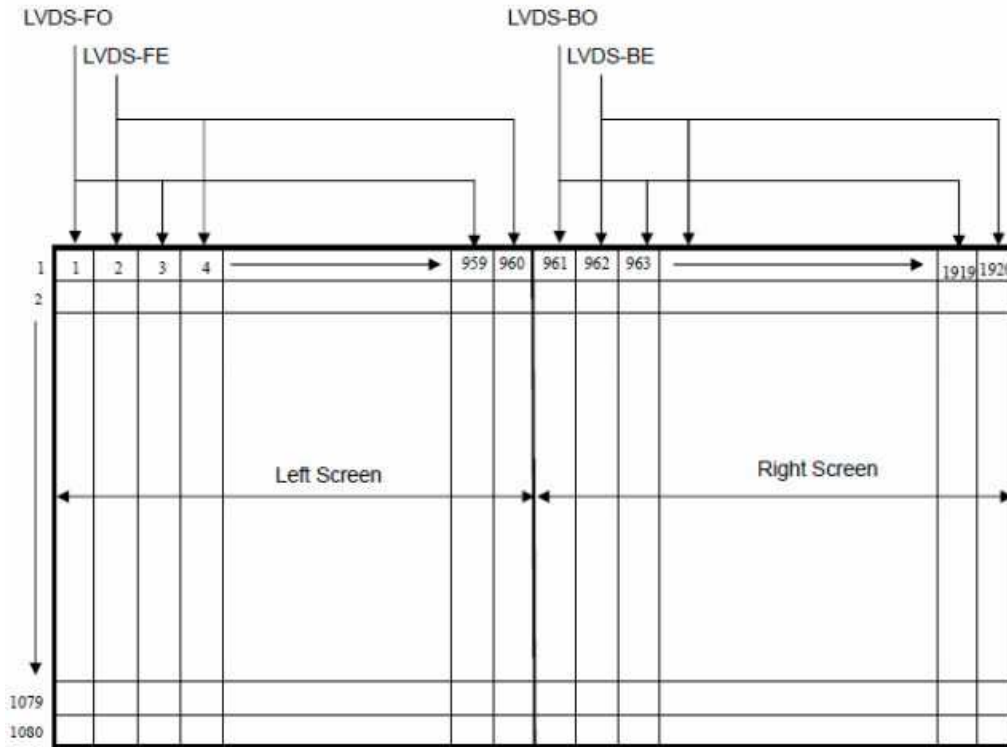

6.2 The input data format

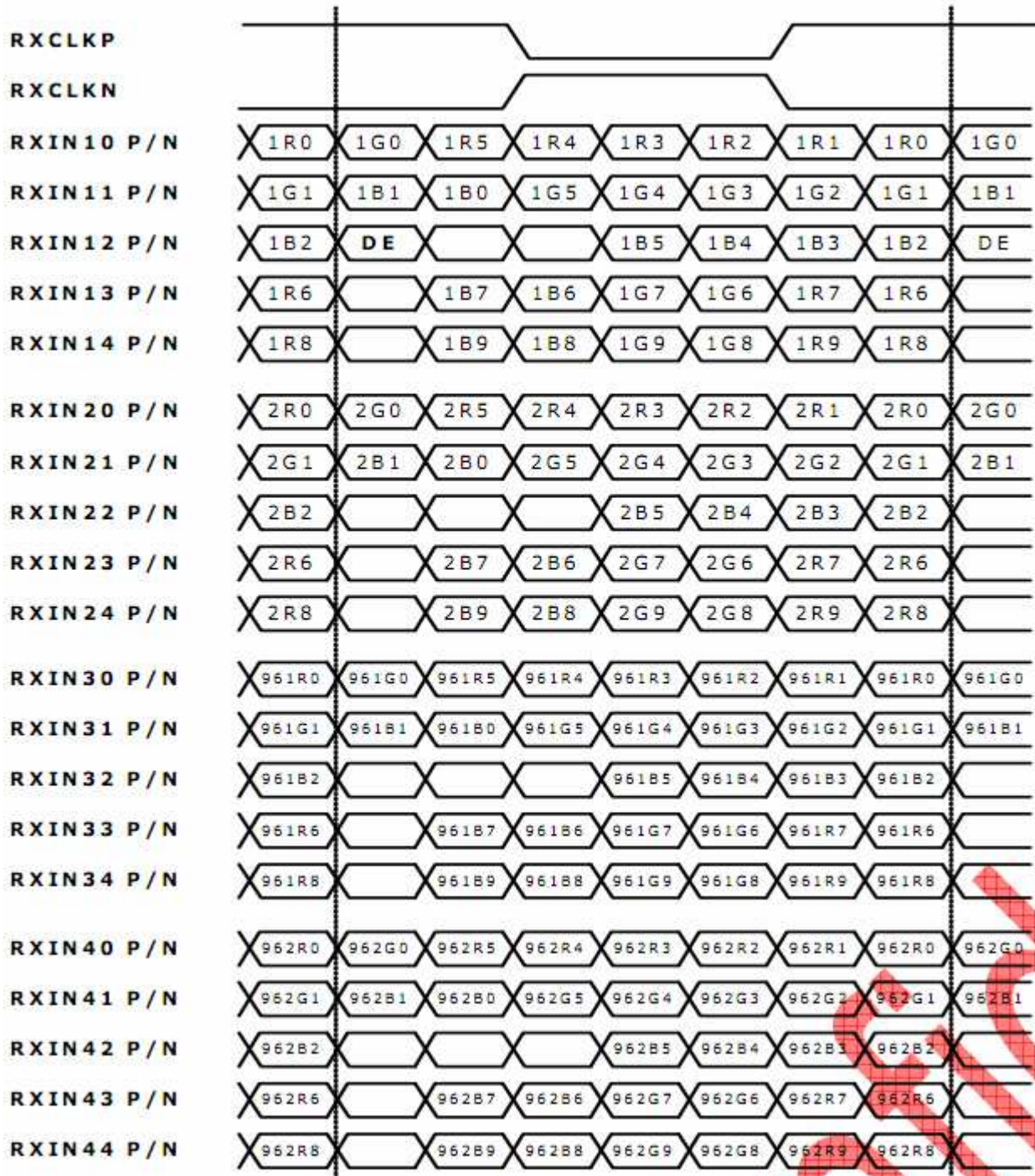

6.3 Signal Description

The module using 51pin 4port LVDS interface. LVDS is a differential signal technology for LCD interface and high speed data transfer device. The first/third LVDS port(RxOxxx) transmits odd pixels while the second/fourth LVDS port(RxExxx) transmits even pixels.

Pin number	Signal name	Description
1	RxO1CN0	F path_ Negative LVDS differential data input (Odd data)
2	RxO1CP0	F path_ Positive LVDS differential data input (Odd data)
3	RxO1CN1	F path_ Negative LVDS differential data input (Odd data)
4	RxO1CP1	F path_ Positive LVDS differential data input (Odd data)
5	RxO1CN2	F path_ Negative LVDS differential data input (Odd data)
6	RxO1CP2	F path_ Positive LVDS differential data input (Odd data)
7	GND	Power Ground
8	RxO1CCLKN	F path_ Negative LVDS differential clock input (Odd clock)
9	RxO1CCLKP	F path_ Positive LVDS differential clock input (Odd clock)
10	GND	Power Ground
11	RxO1CN3	F path_ Negative LVDS differential data input (Odd data)
12	RxO1CP3	F path_ Positive LVDS differential data input (Odd data)
13	GND	Power Ground
14	RxE2CN0	F path_ Negative LVDS differential data input (Even data)
15	RxE2CP0	F path_ Positive LVDS differential data input (Even data)
16	RxE2CN1	F path_ Negative LVDS differential data input (Even data)
17	RxE2CP1	F path_ Positive LVDS differential data input (Even data)
18	RxE2CN2	F path_ Negative LVDS differential data input (Even data)
19	RxE2CP2	F path_ Positive LVDS differential data input (Even data)
20	GND	Power Ground
21	RxE2CCLKN	F path_ Negative LVDS differential clock input (Even clock)
22	RxE2CCLKP	F path_ Positive LVDS differential clock input (Even clock)
23	GND	Power Ground
24	RxE2CN3	F path_ Negative LVDS differential data input (Even data)
25	RxE2CP3	F path_ Positive LVDS differential data input (Even data)
26	GND	Power Ground
27	RxO3CN0	B path_ Negative LVDS differential data input (Odd data)
28	RxO3CP0	B path_ Positive LVDS differential data input (Odd data)
29	RxO3CN1	B path_ Negative LVDS differential data input (Odd data)
30	RxO3CP1	B path_ Positive LVDS differential data input (Odd data)
31	RxO3CN2	B path_ Negative LVDS differential data input (Odd data)
32	RxO3CP2	B path_ Positive LVDS differential data input (Odd data)
33	GND	Power Ground

34	RxO3CCLKN	B path_ Negative LVDS differential clock input (Odd clock)
35	RxO3CCLKP	B path_ Positive LVDS differential clock input (Odd clock)
36	GND	Power Ground
37	RxO3CN3	B path_ Negative LVDS differential data input (Odd data)
38	RxO3CP3	B path_ Positive LVDS differential data input (Odd data)
39	GND	Power Ground
40	RxE4CN0	B path_ Negative LVDS differential data input (Even data)
41	RxE4CP0	B path_ Positive LVDS differential data input (Even data)
42	RxE4CN1	B path_ Negative LVDS differential data input (Even data)
43	RxE4CP1	B path_ Positive LVDS differential data input (Even data)
44	RxE4CN2	B path_ Negative LVDS differential data input (Even data)
45	RxE4CP2	B path_ Positive LVDS differential data input (Even data)
46	GND	Power Ground
47	RxE4CCLKN	B path_ Negative LVDS differential clock input (Even clock)
48	RxE4CCLKP	B path_ Positive LVDS differential clock input (Even clock)
49	GND	Power Ground
50	RxE4CN3	B path_ Negative LVDS differential data input (Even data)
51	RxE4CP3	B path_ Positive LVDS differential data input (Even data)

VDD

Pin number	Signal name	Description
1	2D_3D SW	For 2D/3D switch
2	NC	Do not connect (for AUO test only.)
3	NC	Do not connect (for AUO test only.)
4	GND	Power Ground
5	GND	Power Ground
6	GND	Power Ground
7	GND	Power Ground
8	NC	Do not connect (for AUO test only.)
9	NC	Do not connect (for AUO test only.)
10	GND	Power Ground
11	VDD	Power +5V
12	VDD	Power +5V
13	VDD	Power +5V
14	VDD	Power +5V
15	VDD	Power +5V

Note1: Start from left side

6.4 Timing Characteristics

The input timing characteristics are shown as the following table.

Item		Symbol	Min	Typ	Max	Unit
Data CLK		Tclk	32	75.9	98 <Note 2>	[MHz]
H section	Period	Th	510	560	600	[Tclk]
	Display Area	Tdisp(h)	480	480	480	[Tclk]
	Blanking	Tblk(h)	30 <Note 2>	80	120	[Tclk]
V section	Period	Tv	1088	1130	1715	[Th]
	Display Area	Tdisp(v)	1080	1080	1080	[Th]
	Blanking	Tblk(v)	8	50	635	[Th]
Frame Rate		F	50		120	[Hz]

Note1 : DE mode only

Note2 : OD function turn off

6.5 Timing diagram

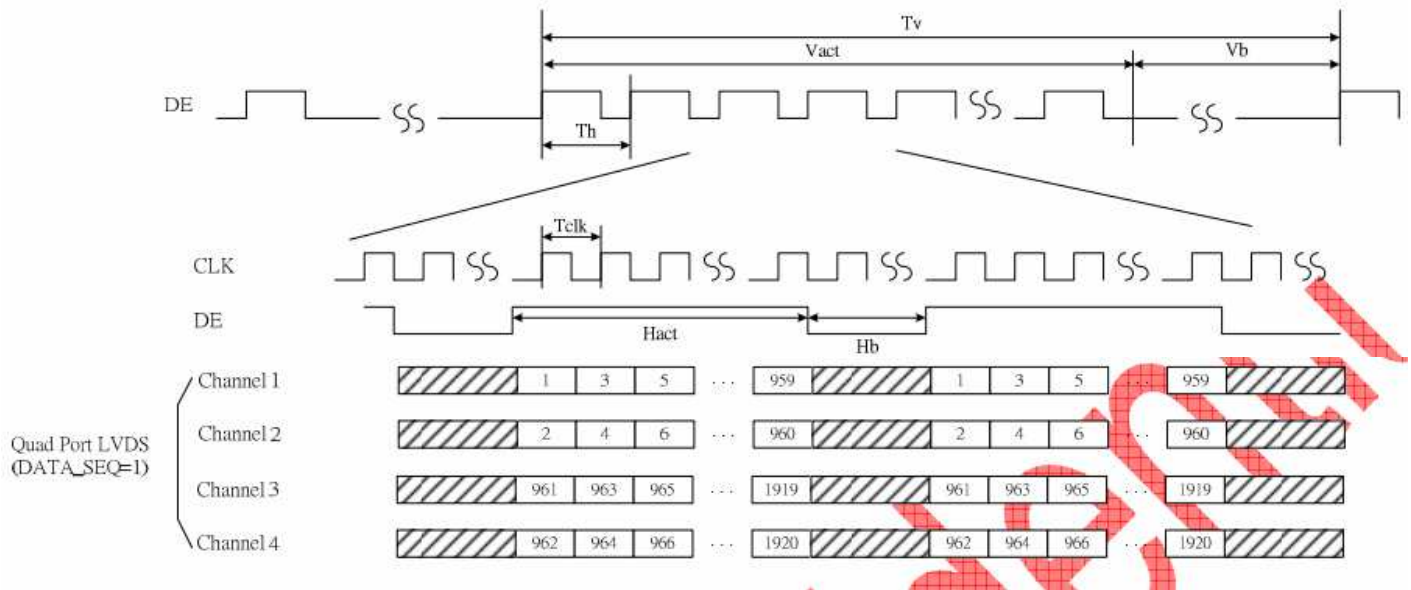

6.6 Power ON/OFF Sequence

VDD power and lamp on/off sequence are as follows. Interface signals are also shown in the chart. Signals from any system shall be Hi Z state or low level when VDD is off.

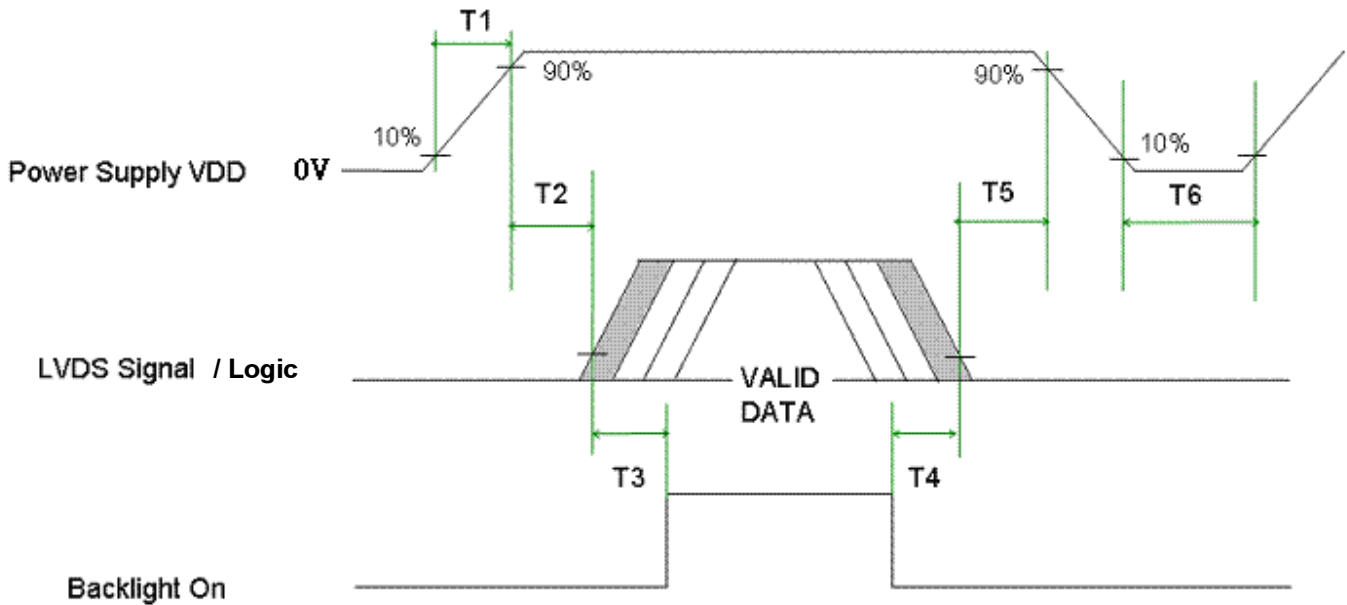

Parameter	Value		Unit
	Min.	Max.	
T1	0.5	10	[msec]
T2	0	50	[msec]
T3	500	-	[msec]
T4	200	-	[msec]
T5	0	50	[msec]
T6	1000	-	[msec]

7.0 Connector & Pin Assignment

Physical interface is described as for the connector on module. These connectors are capable of accommodating the following signals and will be following components.

7.1 TFT LCD Module

LVDS

Connector Name / Designation	Interface Connector / Interface card
Manufacturer	JAE
Type Part Number	FI-RE51S-HF
Mating Housing Part Number	JAE FI-RE51HL

VDD

Connector Name / Designation	Interface Connector / Interface card
Manufacturer	YEONHO
Type Part Number	12507WR-H15L
Mating Housing Part Number	YEONHO 12507HS-H15L

7.1.1 Pin Assignment

LVDS

Pin number	Signal name	Pin number	Signal name
1	RxO1CN0	26	GND
2	RxO1CP0	27	RxO3CN0
3	RxO1CN1	28	RxO3CP0
4	RxO1CP1	29	RxO3CN1
5	RxO1CN2	30	RxO3CP1
6	RxO1CP2	31	RxO3CN2
7	GND	32	RxO3CP2
8	RxO1CCLKN	33	GND
9	RxO1CCLKP	34	RxO3CCLKN
10	GND	35	RxO3CCLKP
11	RxO1CN3	36	GND
12	RxO1CP3	37	RxO3CN3
13	GND	38	RxO3CP3

14	RxE2CN0	39	GND
15	RxE2CP0	40	RxE4CN0
16	RxE2CN1	41	RxE4CP0
17	RxE2CP1	42	RxE4CN1
18	RxE2CN2	43	RxE4CP1
19	RxE2CP2	44	RxE4CN2
20	GND	45	RxE4CP2
21	RxE2CCLKN	46	GND
22	RxE2CCLKP	47	RxE4CCLKN
23	GND	48	RxE4CCLKP
24	RxE2CN3	49	GND
25	RxE2CP3	50	RxE4CN3
		51	RxE4CP3

VDD

Pin number	Signal name	Pin	Signal name
1	2D_3D SW	9	NC
2	NC	10	GND
3	NC	11	VDD
4	GND	12	VDD
5	GND	13	VDD
6	GND	14	VDD
7	GND	15	VDD
8	NC		

7.2 Connector on Backlight Unit.

This connector is mounted on LED light bar.

Connector Name / Designation	Light Bar Connector
Manufacturer	ENTERY INDUSTRIAL CO., LTD
Type Part Number	3707K-Q06N-01R

7.2.1 Pin assignment

Upper Light Bar

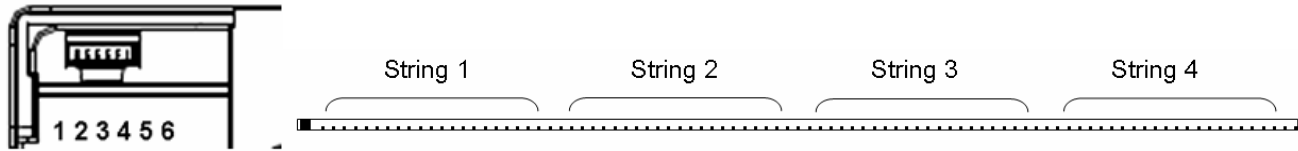

Pin no.	Signal name
1	IRLED (current out) String 4
2	IRLED (current out) String 3
3	VLED (voltage in)
4	VLED (voltage in)
5	IRLED (current out) String 2
6	IRLED (current out) String 1

Lower Light Bar

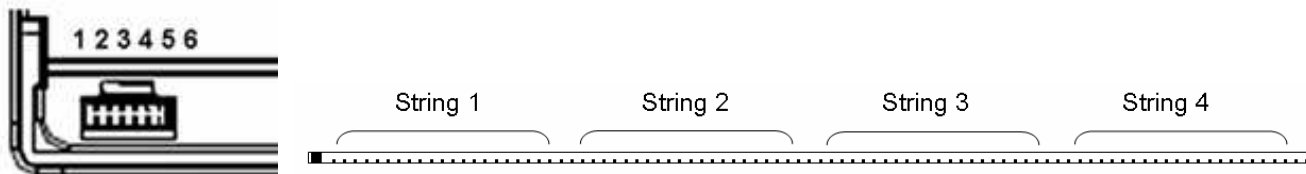

Pin no.	Signal name
1	IRLED (current out) String 2
2	IRLED (current out) String 1
3	VLED (voltage in)
4	VLED (voltage in)
5	IRLED (current out) String 4
6	IRLED (current out) String 3



8.0 Reliability Test

Environment test conditions are listed as following table.

Items	Required Condition	Note
Temperature Humidity Bias (THB)	Ta= 50°C , 80%RH, 300hours	
High Temperature Operation (HTO)	Ta= 50°C , 50%RH, 300hours	
Low Temperature Operation (LTO)	Ta= 0°C , 300hours	
High Temperature Storage (HTS)	Ta= 60°C , 300hours	
Low Temperature Storage (LTS)	Ta= -20°C , 300hours	
Vibration Test (Non-operation)	Acceleration: 1.5 Grms Wave: Random Frequency: 10 - 200 Hz Duration: 30 Minutes each Axis (X, Y, Z)	
Shock Test (Non-operation)	Acceleration: 50 G Wave: Half-sine Active Time: 20 ms Direction: ±X, ±Y, ±Z (one time for each Axis)	
Drop Test	Height: 46 cm, package test	
Thermal Shock Test (TST)	-20□/30min, 60□/30min, 100 cycles	1
On/Off Test	On/10sec, Off/10sec, 30,000 cycles	
ESD (Electro Static Discharge)	Contact Discharge: ± 8KV, 150pF(330Ω) 1sec, 15 points, 25 times/ point.	2
	Air Discharge: ± 15KV, 150pF(330Ω) 1sec 15 points, 25 times/ point.	
Altitude Test	Operation:10,000 ft Non-Operation:30,000 ft	

Note 1: The TFT-LCD module will not sustain damage after being subjected to 100 cycles of rapid temperature change. A cycle of rapid temperature change consists of varying the temperature from -20□ to 60□, and back again. Power is not applied during the test. After temperature cycling, the unit is placed in normal room ambient for at least 4 hours before power on.

Note 2: EN61000-4-2, ESD class B: Certain performance degradation allowed
Self-recoverable

No data lost
No hardware failures.

9.0 Shipping Label

The label is on the panel as shown below:

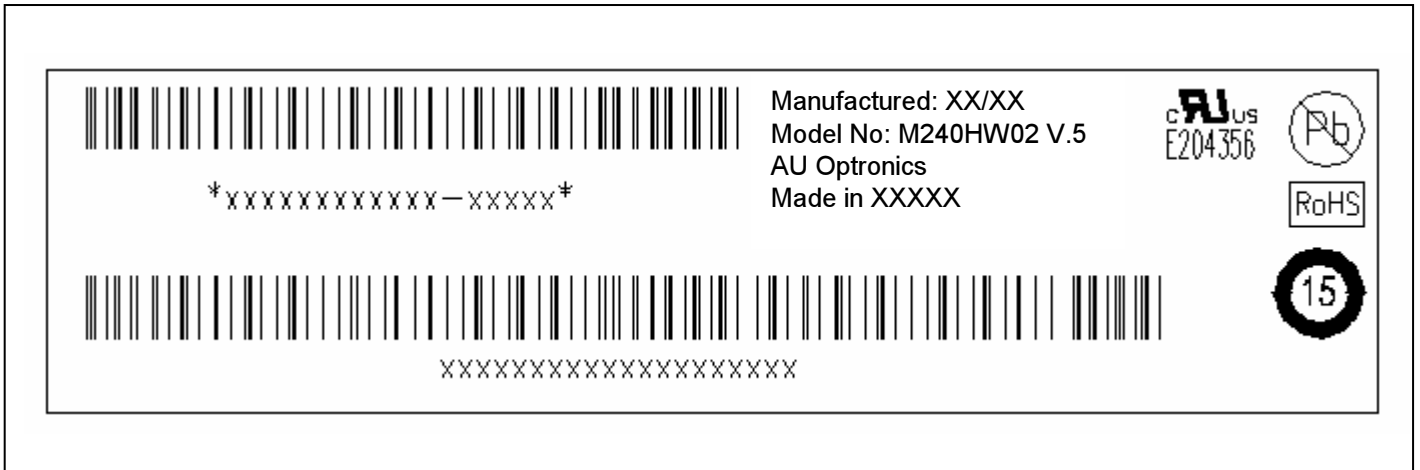

Note 1: For Pb Free products, AUO will add  for identification.

Note 2: For RoHS compatible products, AUO will add  for identification.

Note 3: For China RoHS compatible products, AUO will add  for identification.

Note 4: The Green Mark will be presented only when the green documents have been ready by AUO Internal Green Team.

10.0 Mechanical Characteristics

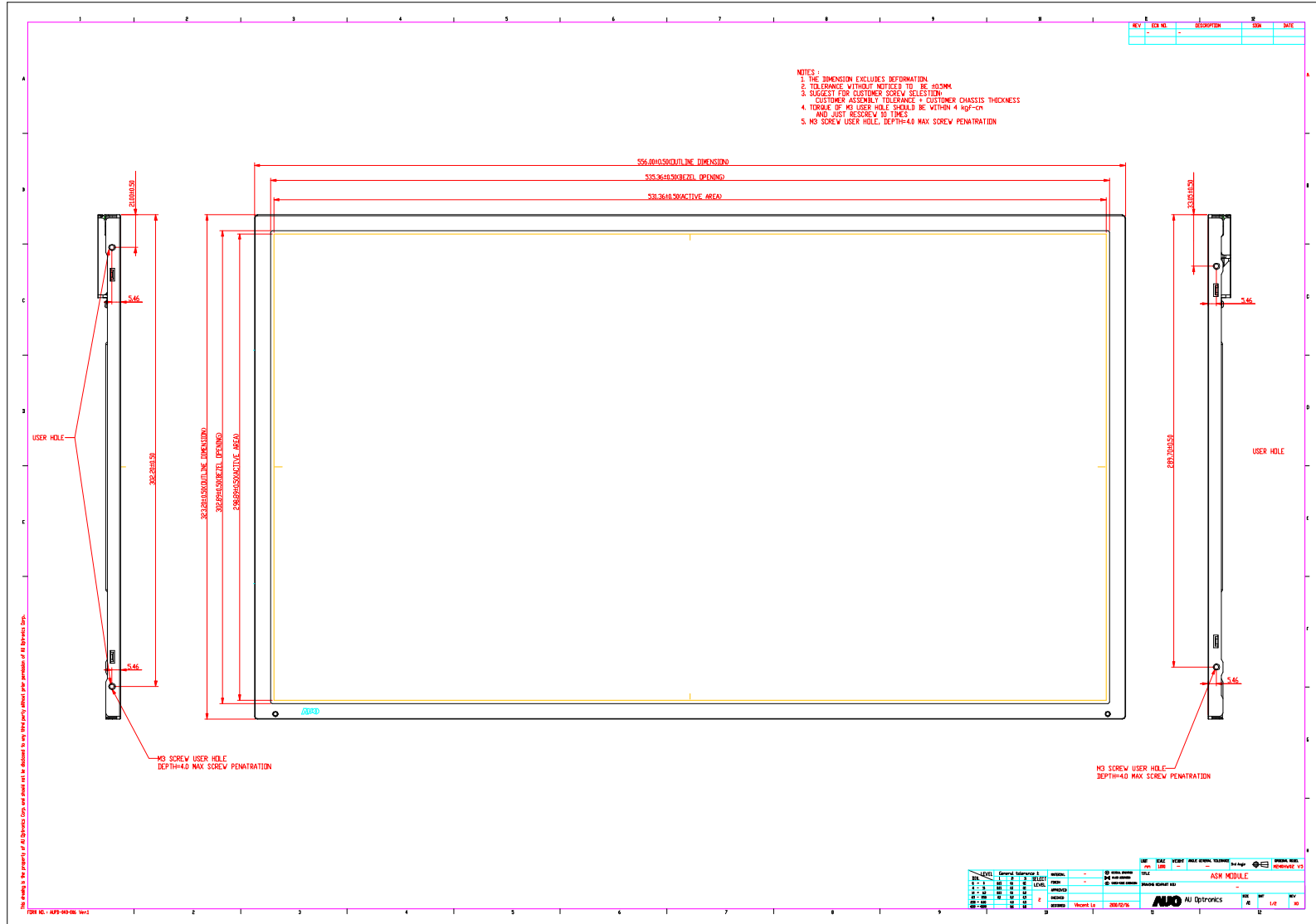

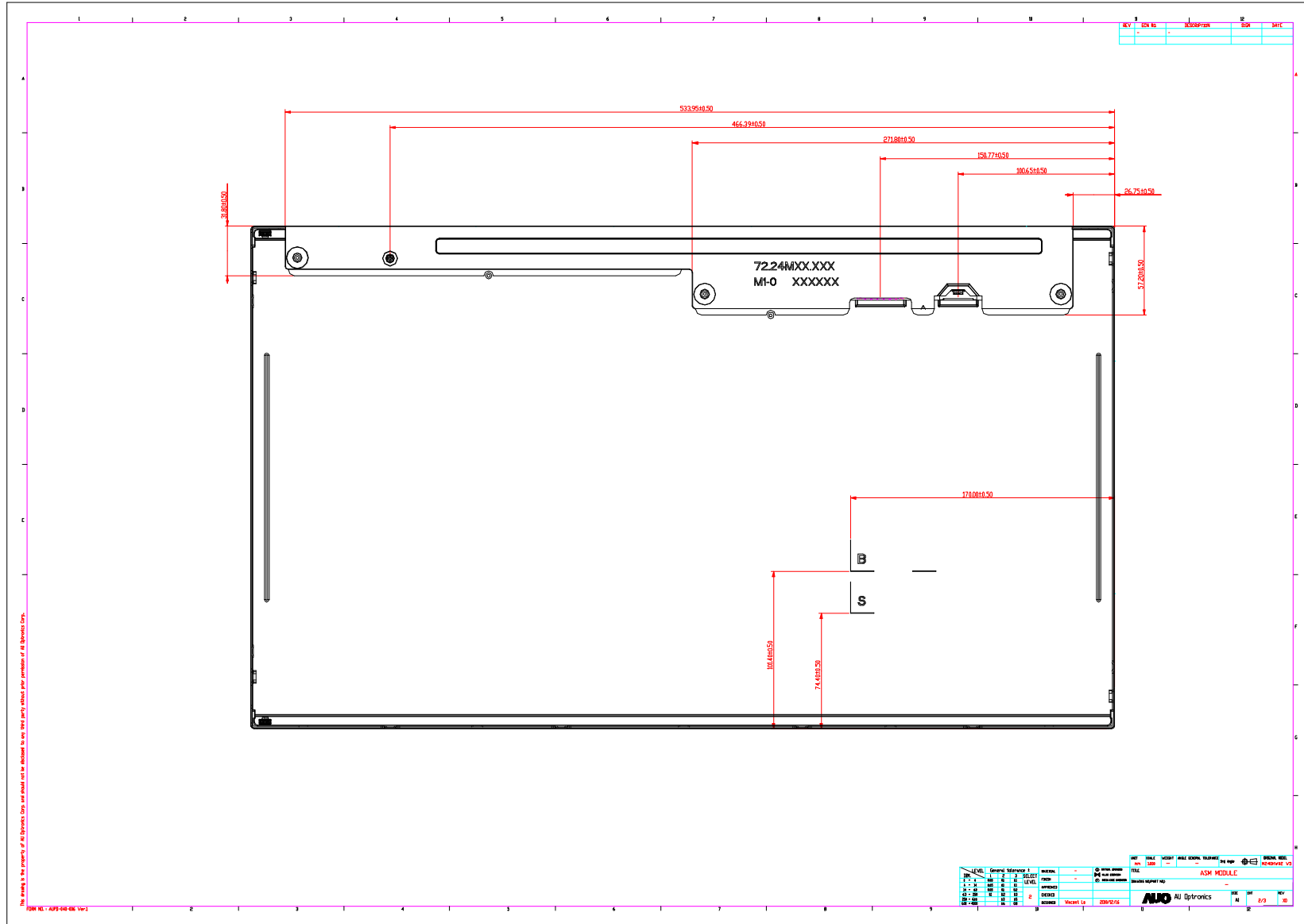

11.0 Packing Specification

1. Package Flow

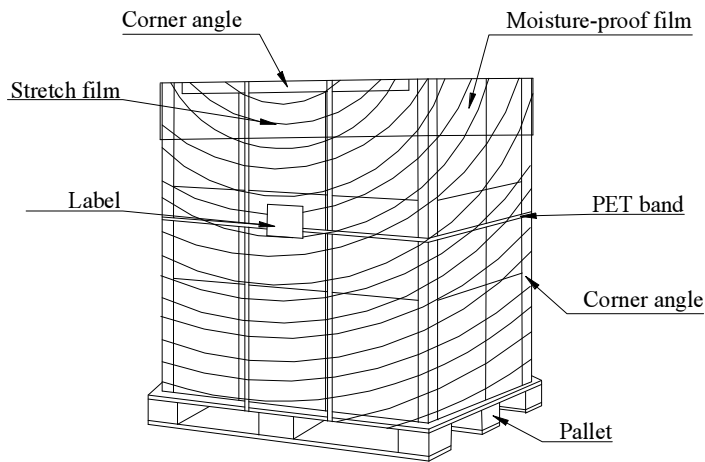
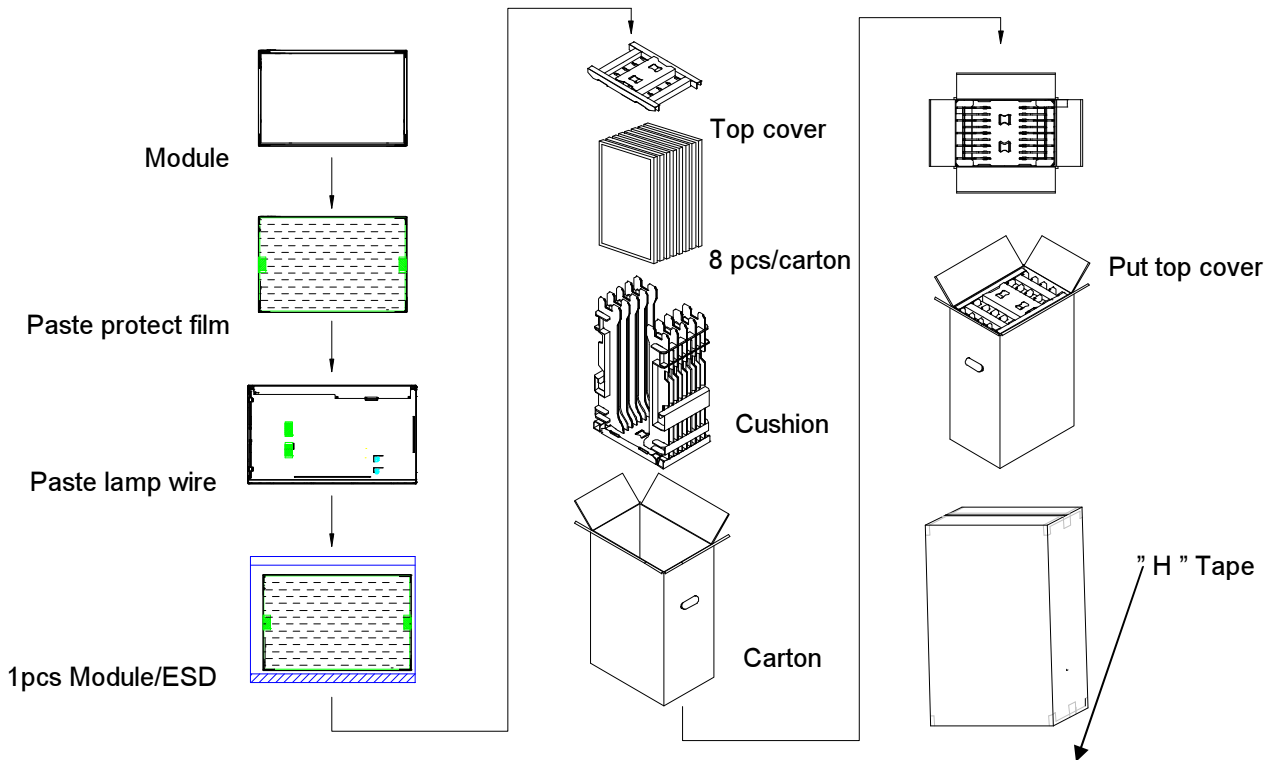

2. Pallet and shipment information

	Item	Specification			Remark
		Q'ty	Dimension	Weight(kg)	
1	Panel	1	556(H)mm x 323(V)mm x 16.3(D)mm	2.75	
2	Cushion	1	-	1.51	
3	Box	1	406(L)mm x 281(W)mm x 651(H)mm	1.185	without Panel & cushion
4	Packing Box	8 pcs/Box	406(L)mm x 281(W)mm x 651(H)mm	24.73	with panel & cushion
5	Pallet	1	1140(L)mm x 830(W)mm x 138(H)mm	12	
6	Pallet after Packing	16 boxes/pallet	1140(L)mm x 830(W)mm x 142.2(H)mm	407.76	