

## TFT LCD Approval Specification

# MODEL NO.: V315B6-P01

Customer: _____
Approved by: _____
Note:

Approved By	TV Product Marketing & Management Div	
	Chao-Chun Chung	

Reviewed By	QRA Dept.	Product Development Div.
	Kc-Ko	WT Lin

Prepared By	LCD TV Marketing and Product Management Div.	
	CY Chang	Lee-Lee Chang

- CONTENTS -

REVISION HISTORY	-----	3
1. GENERAL DESCRIPTION	-----	4
1.1 OVERVIEW		
1.2 CHARACTERISTICS		
1.3 MECHANICAL SPECIFICATIONS		
2. ABSOLUTE MAXIMUM RATINGS	-----	5
2.1 ABSOLUTE RATINGS OF ENVIRONMENT (BASED ON CMO MODULE V315B6-L02)		
2.2 ABSOLUTE RATINGS OF ENVIRONMENT (OPEN CELL)		
2.3 ELECTRICAL ABSOLUTE RATINGS (OPEN CELL)		
3. ELECTRICAL CHARACTERISTICS	-----	7
3.1 TFT LCD OPEN CELL		
4. BLOCK DIAGRAM	-----	9
4.1 TFT LCD OPEN CELL		
5. INPUT TERMINAL PIN ASSIGNMENT	-----	10
5.1 TFT LCD OPEN CELL		
5.2 BLOCK DIAGRAM OF INTERFACE		
5.3 LVDS INTERFACE		
5.4 COLOR DATA INPUT ASSIGNMENT		
5.5 PATTERN FOR Vcom ADJUSTMENT		
6. INTERFACE TIMING	-----	16
6.1 INPUT SIGNAL TIMING SPECIFICATIONS		
6.2 POWER ON/OFF SEQUENCE		
7. OPTICAL CHARACTERISTICS	-----	20
7.1 TEST CONDITIONS		
7.2 OPTICAL SPECIFICATIONS		
8. DEFINITION OF LABELS	-----	23
8.1 OPEN CELL LABEL		
8.2 CARTON LABEL		
9. PACKAGING	-----	24
9.1 PACKING SPECIFICATIONS		
9.2 PACKING METHOD		
10. PRECAUTIONS	-----	26
10.1 ASSEMBLY AND HANDLING PRECAUTIONS		
10.2 SAFETY PRECAUTIONS		
11. MECHANICAL DRAWING	-----	27

**REVISION HISTORY**

<b>Version</b>	<b>Date</b>	<b>Page (New)</b>	<b>Section</b>	<b>Description</b>
Ver 2.1	Sep.,28, 09'	All	All	Approval Specification was first issued.

## 1. GENERAL DESCRIPTION

### 1.1 OVERVIEW

V315B6- P01 is a 31.5" TFT Liquid Crystal Display module. This module supports 1366 x 768 WXGA format and can display 16.7M (8-bit/color) colors.

### 1.2 CHARACTERISTICS

CHARACTERISTICS ITEMS	SPECIFICATIONS
Screen Diagonal [in]	31.5"
Pixels [lines]	1366 × 768
Active Area [mm]	697.6845 (H) x 392.256 (V) (31.5" diagonal)
Sub -Pixel Pitch [mm]	0.17025 (H) x 0.51075 (V)
Pixel Arrangement	RGB vertical stripe
Weight [g]	TYP. 1150
Physical Size [mm]	716.1(W) x 410(H) x 1.8(D) Typ.
Display Mode	Transmissive mode / Normally black
Contrast Ratio	3000:1 Typ. (Typical value measured at CMO's module: V315B6-L01)
Glass thickness (Array/CF) [mm]	0.7 / 0.7
Viewing Angle (CR>20)	+88/-88(H),+88/-88(V) Typ. (Typical value measured at CMO's module: V315B6-L01)
Color Chromaticity	R=0.642, 0.332 G=0.277, 0.598 B=0.145, 0.066 W=0.285, 0.293 (Typical value measured at CMO's module: V315B6-L01)
Cell Transparency [%]	5.8%Typ. (Typical value measured at CMO's module: V315B6-L01)
Polarizer (CF side)	Super Wide View Anti-glare coating, 709.7(H) x 405(W) Haze:11% Hardness:3H
Polarizer (TFT side)	Super Wide View, 709.7(H) x 405(W). Haze:11% Hardness:3H

### 1.3 MECHANICAL SPECIFICATIONS

Item	Min.	Typ.	Max.	Unit	Note
Weight		1150		g	-
I/F connector mounting position	The mounting inclination of the connector makes the screen center within ±0.5mm as the horizontal.				(2)

Note (1) Please refer to the attached drawings for more information of front and back outline dimensions.

(2) Connector mounting position

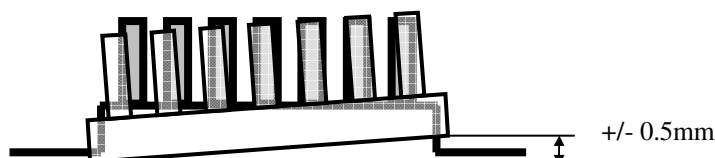

## 2. ABSOLUTE MAXIMUM RATINGS

### 2.1 ABSOLUTE RATINGS OF ENVIRONMENT (BASED ON CMO MODULE V315B6-L02)

Item	Symbol	Value		Unit	Note
		Min.	Max.		
Storage Temperature	T <sub>ST</sub>	-20	+60	°C	(1), (3)
Operating Ambient Temperature	T <sub>OP</sub>	0	50	°C	(1), (2), (3)
Altitude Operating	A <sub>OP</sub>	0	5000	M	(3)
Altitude Storage	A <sub>ST</sub>	0	12000	M	(3)

Note (1) Temperature and relative humidity range is shown in the figure below.

- (a) 90 %RH Max. ( $T_a \leq 40$  °C).
- (b) Wet-bulb temperature should be 39 °C Max. ( $T_a > 40$  °C).
- (c) No condensation.

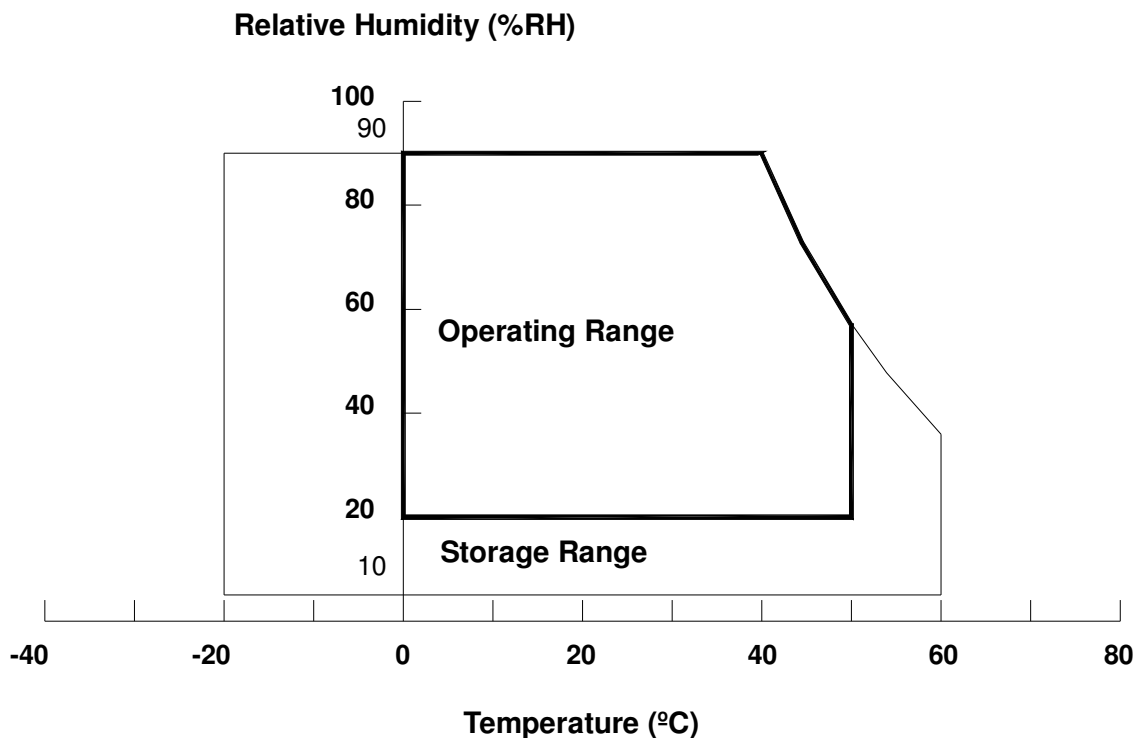

Note (2) The maximum operating temperature is based on the test condition that the surface temperature of display area is less than or equal to 65 °C with LCD module alone in a temperature controlled chamber. Thermal management should be considered in your product design to prevent the surface temperature of display area from being over 65 °C. The range of operating temperature may degrade in case of improper thermal management in your product design.

Note (3) The rating of environment is base on LCD module. Leave LCD cell alone, this environment condition can't be guaranteed. Except LCD cell, the customer has to consider the ability of other parts of LCD module and LCD module process.

## 2.2 ABSOLUTE RATINGS OF ENVIRONMENT (OPEN CELL)

Storage Condition: With shipping package.

Storage temperature range: 25±5 °C

Storage humidity range: 50±10%RH

Shelf life: a month

## 2.3 ELECTRICAL ABSOLUTE RATINGS

### 2.3.1 TFT LCD OPEN CELL

Item	Symbol	Value		Unit	Note
		Min.	Max.		
Power Supply Voltage	V <sub>CC</sub>	-0.3	13.5	V	(1)
Input Signal Voltage	V <sub>IN</sub>	-0.3	3.6	V	

Note (1) Permanent damage to the device may occur if maximum values are exceeded. Functional operation should be restricted to the conditions described under normal operating conditions.

### 3. ELECTRICAL CHARACTERISTICS

#### 3.1 TFT LCD OPEN CELL

Ta = 25 ± 2°C

Parameter	Symbol	Value			Unit	Note	
		Min.	Typ.	Max.			
Power Supply Voltage	V <sub>CC</sub>	10.8	12.0	13.2	V	(1)	
Rush Current	I <sub>RUSH</sub>	-	-	3.3	A	(2)	
Power Supply Current	White	-	0.51	-	A	(3)	
	Horizontal Stripe	-	0.6	0.72	A		
	Black	-	0.4	-	A		
LVDS Interface	Differential Input High Threshold Voltage	V <sub>LVTH</sub>	+100	-	-	mV	(4)
	Differential Input Low Threshold Voltage	V <sub>LVTL</sub>	-	-	-100	mV	
	Common Input Voltage	V <sub>CM</sub>	1.0	1.2	1.4	V	
	Differential input voltage	V <sub>ID</sub>	200	-	600	mV	
	Terminating Resistor	R <sub>T</sub>	-	100	-	ohm	
CMOS interface	Input High Threshold Voltage	V <sub>IH</sub>	2.7	-	3.3	V	
	Input Low Threshold Voltage	V <sub>IL</sub>	0	-	0.7	V	

Note (1) The module should be always operated within above ranges.

Note (2) Measurement Conditions:

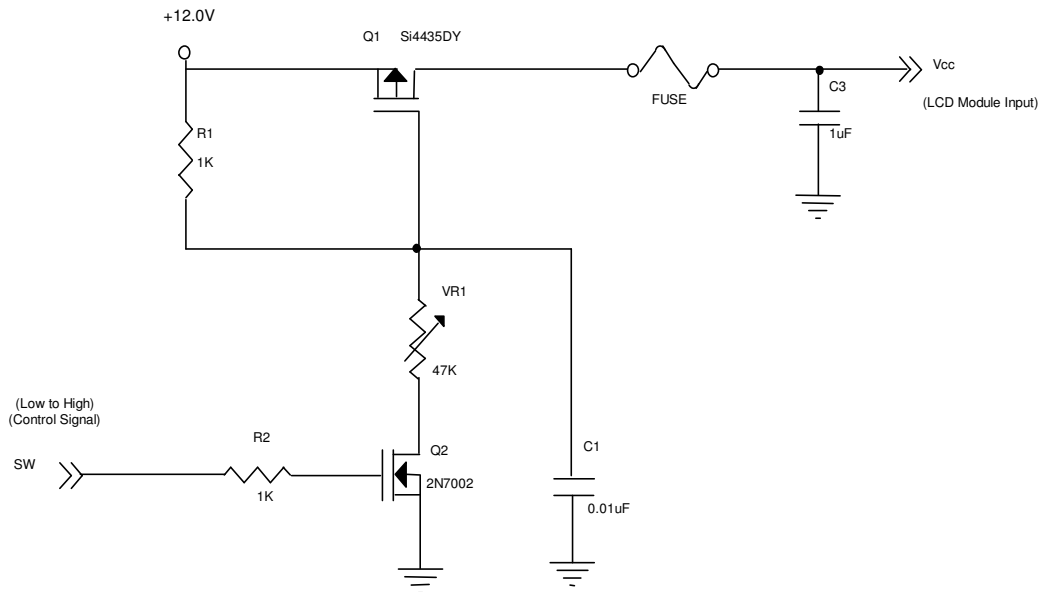

**Vcc rising time is 470us**

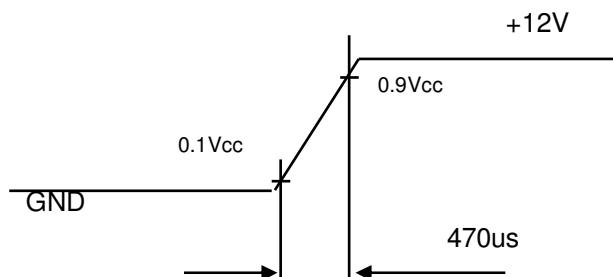

Note (3) The specified power supply current is under the conditions at  $V_{CC} = 12V$ ,  $T_a = 25 \pm 2 \text{ }^\circ\text{C}$ ,  $f_v = 60$  Hz, whereas a power dissipation check pattern below is displayed.

a. White Pattern



Active Area

b. Black Pattern



Active Area

c. Vertical Stripe Pattern

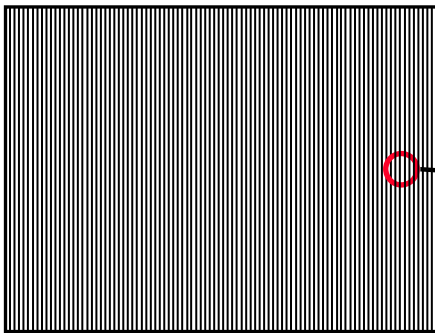

Active Area

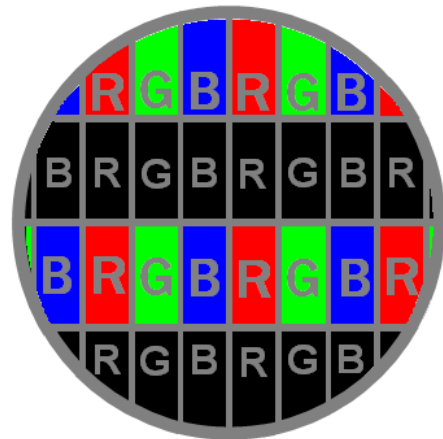

Note (4) The LVDS input characteristics are as follows:

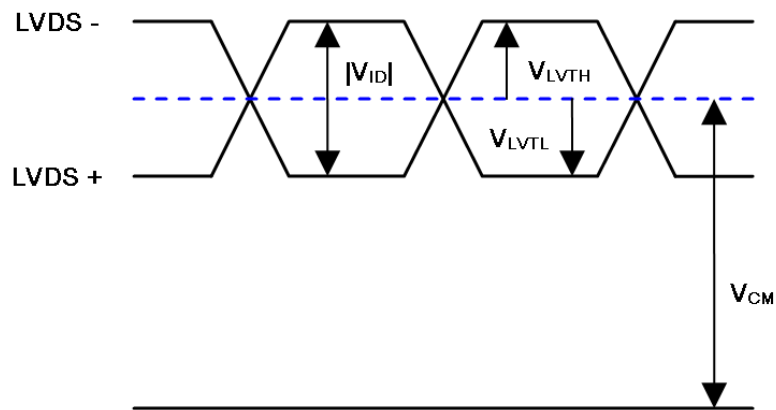



**4. BLOCK DIAGRAM**

**4.1 TFT LCD OPEN CELL**

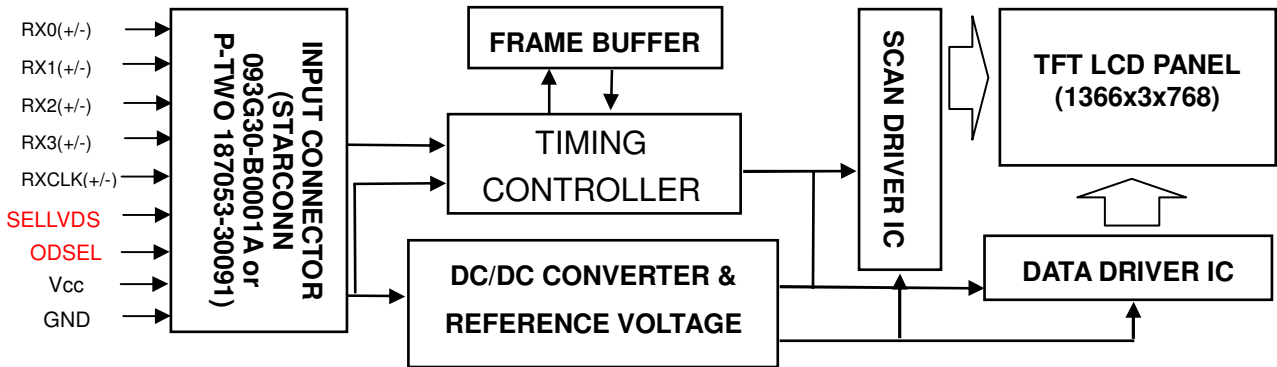

## 5. INTERFACE PIN CONNECTION

### 5.1 TFT LCD OPEN CELL

#### CNF1 Connector Pin Assignment

Pin No.	Symbol	Description	Note
1	VCC	Power supply: +12V	
2	VCC	Power supply: +12V	
3	VCC	Power supply: +12V	
4	VCC	Power supply: +12V	
5	GND	Ground	
6	GND	Ground	
7	GND	Ground	
8	GND	Ground	
9	SELLVDS	Select LVDS data format	(2)(6)
10	ODSEL	Overdrive Lookup Table Selection	(3)(6)
11	GND	Ground	
12	RX0-	Negative transmission data of pixel 0	
13	RX0+	Positive transmission data of pixel 0	
14	GND	Ground	
15	RX1-	Negative transmission data of pixel 1	
16	RX1+	Positive transmission data of pixel 1	
17	GND	Ground	
18	RX2-	Negative transmission data of pixel 2	
19	RX2+	Positive transmission data of pixel 2	
20	GND	Ground	
21	RXCLK-	Negative of clock	
22	RXCLK+	Positive of clock	
23	GND	Ground	
24	RX3-	Negative transmission data of pixel 3	
25	RX3+	Positive transmission data of pixel 3	
26	GND	Ground	
27	TST_AGE	Aging Mode	(4)
28	NC	No connection	(5)
29	GND	Ground	
30	GND	Ground	

Note (1) Connector type: STARCONN 093G30-B0001A or P-TWO 187053-30091 or compatible

LVDS connector pin order defined as follows

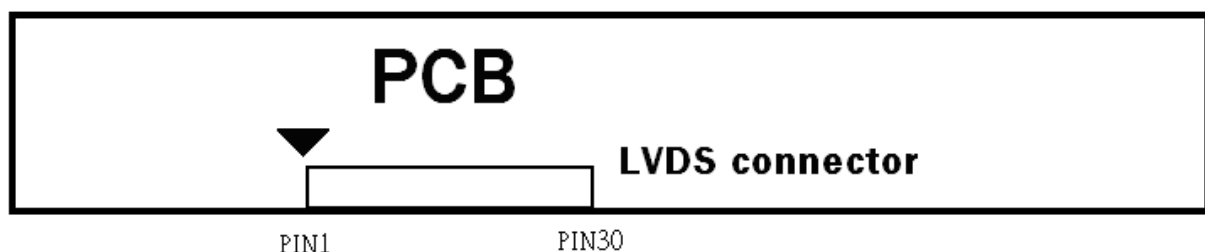

Note (2) Low = Open or connect to GND: VESA Format, High = Connect to +3.3V: JEIDA Format.

Please refer to 5.5 LVDS INTERFACE

Note (3) Overdrive lookup table selection. The Overdrive lookup table should be selected in accordance to the frame rate to optimize image quality.

Low = Open or connect to GND, High = Connect to +3.3V

ODSEL	Note
L or Open	Lookup table was optimized for 60 Hz frame rate.
H	Lookup table was optimized for 50 Hz frame rate.

Note (4) Ground or OPEN: Disable, High: Enable.

Note (5) Reserved for internal use. Left it open.

Note (6) LVDS signal pin connected to the LCM side has the following diagram.

R1 in the system side should be less than 1K Ohm. ( $R1 < 1K \text{ Ohm}$ )

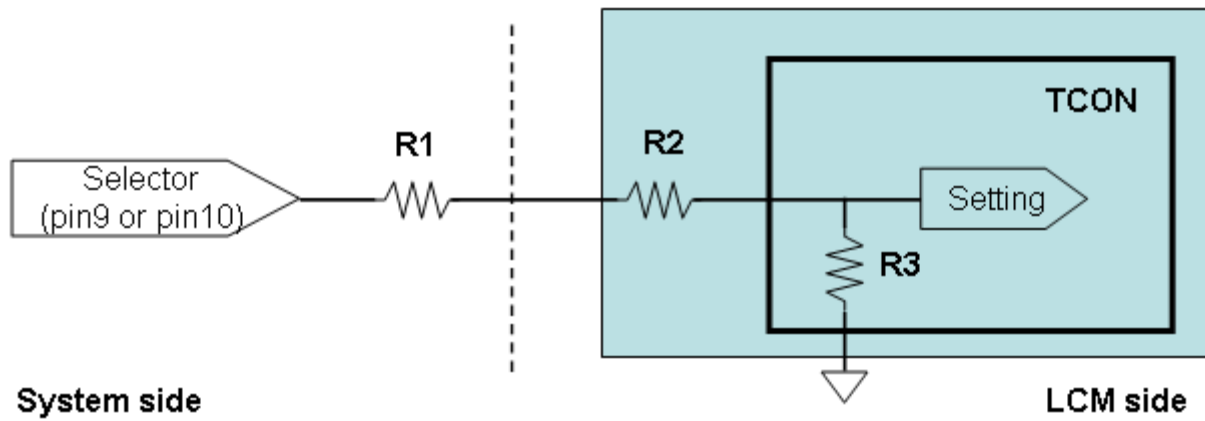

## 5.2 BLOCK DIAGRAM OF INTERFACE

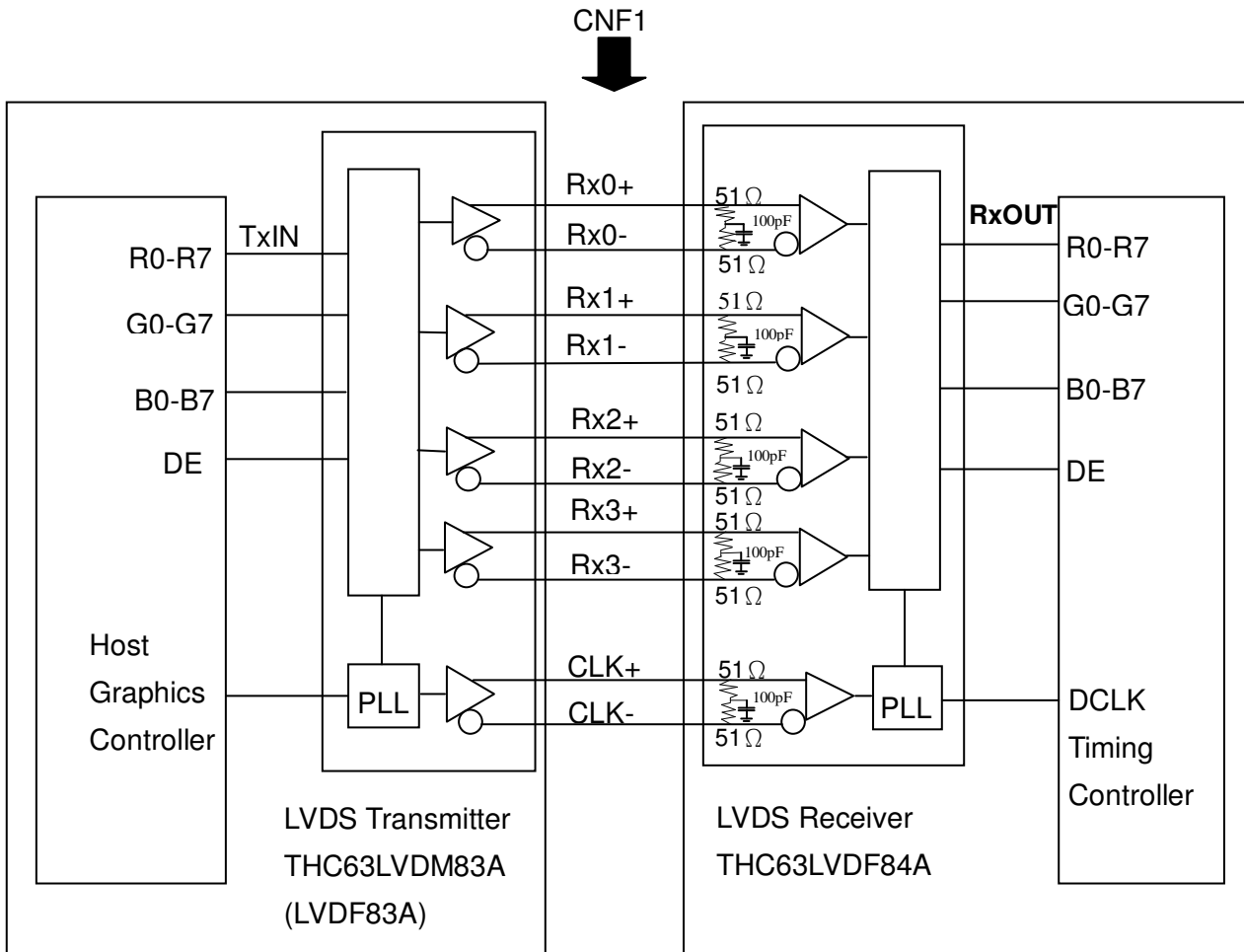

- R0~R7 : Pixel R Data
- G0~G7 : Pixel G Data
- B0~B7 : Pixel B Data
- DE : Data enable signal
- DCLK : Data clock signal

Note (1) The system must have the transmitter to drive the module.

Note (2) LVDS cable impedance shall be 50 ohms per signal line or about 100 ohms per twist-pair line when it is used differentially.

### 5.3 LVDS INTERFACE

VESA LVDS format : (SELLVDS pin=L or open)

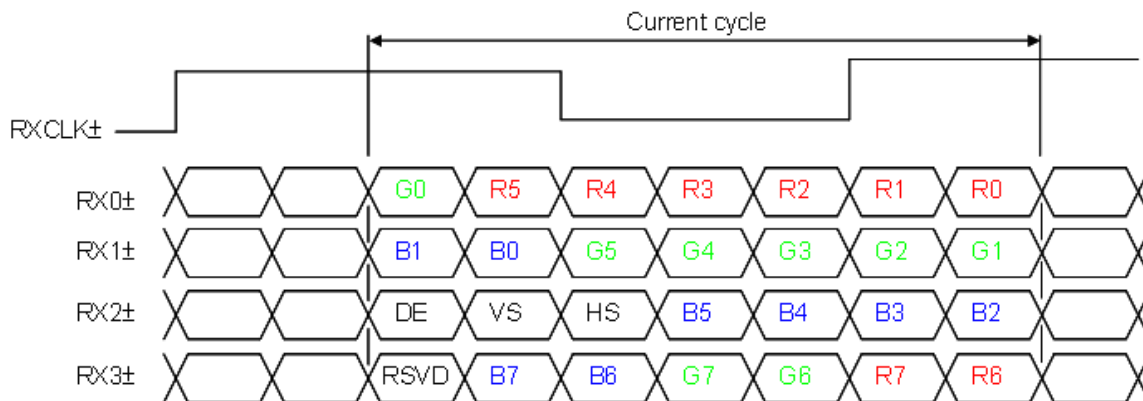

JEDIA LVDS format : (SELLVDS pin=H)

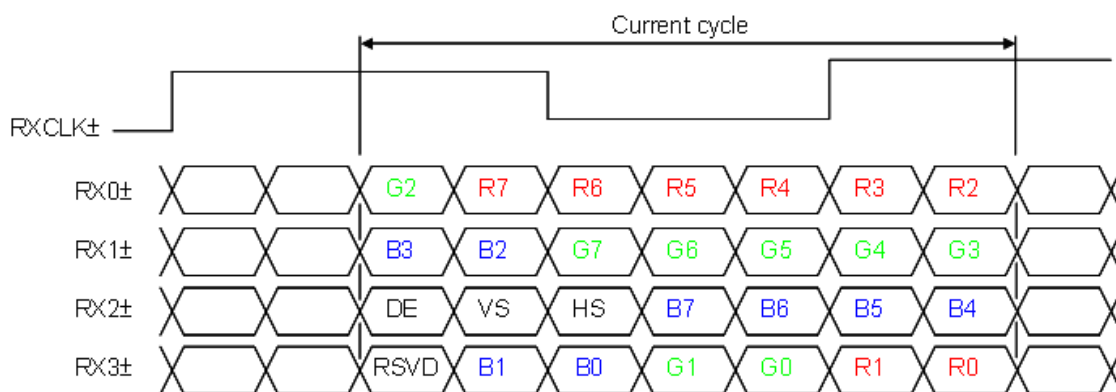

R0~R7: Pixel R Data (7; MSB, 0; LSB)

G0~G7: Pixel G Data (7; MSB, 0; LSB)

B0~B7: Pixel B Data (7; MSB, 0; LSB)

DE: Data enable signal

Note (1) RSVD(reserved)pins on the transmitter shall be "H" or ("L" or OPEN)

### 5.4 COLOR DATA INPUT ASSIGNMENT

The brightness of each primary color (red, green and blue) is based on the 8-bit gray scale data input for the color. The higher the binary input, the brighter the color. The table below provides the assignment of color versus data input.

Color		Data Signal																							
		Red								Green								Blue							
		R7	R6	R5	R4	R3	R2	R1	R0	G7	G6	G5	G4	G3	G2	G1	G0	B7	B6	B5	B4	B3	B2	B1	B0
Basic Colors	Black	0	0	0	0	0	0	0	0	0	0	0	0	0	0	0	0	0	0	0	0	0	0	0	
	Red	1	1	1	1	1	1	1	1	0	0	0	0	0	0	0	0	0	0	0	0	0	0	0	
	Green	0	0	0	0	0	0	0	0	1	1	1	1	1	1	1	0	0	0	0	0	0	0	0	
	Blue	0	0	0	0	0	0	0	0	0	0	0	0	0	0	0	1	1	1	1	1	1	1	1	
	Cyan	0	0	0	0	0	0	0	0	1	1	1	1	1	1	1	1	1	1	1	1	1	1	1	
	Magenta	1	1	1	1	1	1	1	1	0	0	0	0	0	0	0	1	1	1	1	1	1	1	1	
	Yellow	1	1	1	1	1	1	1	1	1	1	1	1	1	1	1	0	0	0	0	0	0	0	0	
	White	1	1	1	1	1	1	1	1	1	1	1	1	1	1	1	1	1	1	1	1	1	1	1	
Gray Scale Of Red	Red(0) / Dark	0	0	0	0	0	0	0	0	0	0	0	0	0	0	0	0	0	0	0	0	0	0		
	Red(1)	0	0	0	0	0	0	1	0	0	0	0	0	0	0	0	0	0	0	0	0	0	0		
	Red(2)	0	0	0	0	0	1	0	0	0	0	0	0	0	0	0	0	0	0	0	0	0	0		
	:	:	:	:	:	:	:	:	:	:	:	:	:	:	:	:	:	:	:	:	:	:	:		
	:	:	:	:	:	:	:	:	:	:	:	:	:	:	:	:	:	:	:	:	:	:	:		
	Red(253)	1	1	1	1	1	1	0	1	0	0	0	0	0	0	0	0	0	0	0	0	0	0		
	Red(254)	1	1	1	1	1	1	1	0	0	0	0	0	0	0	0	0	0	0	0	0	0	0		
	Red(255)	1	1	1	1	1	1	1	1	0	0	0	0	0	0	0	0	0	0	0	0	0	0		
Gray Scale Of Green	Green(0) / Dark	0	0	0	0	0	0	0	0	0	0	0	0	0	0	0	0	0	0	0	0	0	0		
	Green(1)	0	0	0	0	0	0	0	0	0	0	0	0	0	0	1	0	0	0	0	0	0	0		
	Green(2)	0	0	0	0	0	0	0	0	0	0	0	0	0	1	0	0	0	0	0	0	0	0		
	:	:	:	:	:	:	:	:	:	:	:	:	:	:	:	:	:	:	:	:	:	:	:		
	:	:	:	:	:	:	:	:	:	:	:	:	:	:	:	:	:	:	:	:	:	:	:		
	Green(253)	0	0	0	0	0	0	0	1	1	1	1	1	1	0	1	0	0	0	0	0	0	0		
	Green(254)	0	0	0	0	0	0	0	1	1	1	1	1	1	1	0	0	0	0	0	0	0	0		
	Green(255)	0	0	0	0	0	0	0	1	1	1	1	1	1	1	1	0	0	0	0	0	0	0		
Gray Scale Of Blue	Blue(0) / Dark	0	0	0	0	0	0	0	0	0	0	0	0	0	0	0	0	0	0	0	0	0	0		
	Blue(1)	0	0	0	0	0	0	0	0	0	0	0	0	0	0	0	0	0	0	0	0	0	1		
	Blue(2)	0	0	0	0	0	0	0	0	0	0	0	0	0	0	0	0	0	0	0	0	1	0		
	:	:	:	:	:	:	:	:	:	:	:	:	:	:	:	:	:	:	:	:	:	:	:		
	:	:	:	:	:	:	:	:	:	:	:	:	:	:	:	:	:	:	:	:	:	:	:		
	Blue(253)	0	0	0	0	0	0	0	0	0	0	0	0	0	0	0	1	1	1	1	1	1	0		
	Blue(254)	0	0	0	0	0	0	0	0	0	0	0	0	0	0	0	1	1	1	1	1	1	0		
	Blue(255)	0	0	0	0	0	0	0	0	0	0	0	0	0	0	0	1	1	1	1	1	1	1		

Note (1) 0: Low Level Voltage, 1: High Level Voltage

### 5.5 PATTERN FOR Vcom ADJUSTMENT

#### 2line-inversion pattern ( 2n+1)

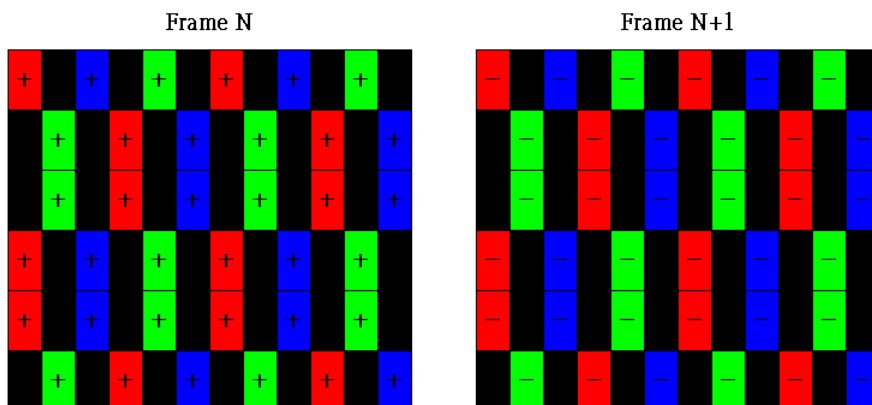

## 6. INTERFACE TIMING

### 6.1 INPUT SIGNAL TIMING SPECIFICATIONS

The input signal timing specifications are shown as the following table and timing diagram.

Signal	Item	Symbol	Min.	Typ.	Max.	Unit	Note
LVDS Receiver Clock	Frequency	$F_{\text{clkin}}$ (=1/TC)	60	76	82	MHz	
	Input cycle to cycle jitter	$T_{\text{rcj}}$	—	—	200	ps	(3)
	Spread spectrum modulation range	$F_{\text{clkin\_mod}}$	$F_{\text{clkin}}-2\%$	—	$F_{\text{clkin}}+2\%$	MHz	(4)
	Spread spectrum modulation frequency	$F_{\text{SSM}}$			200	KHz	
LVDS Receiver Data	Setup Time	$T_{\text{lvsu}}$	600	—	—	ps	(5)
	Hold Time	$T_{\text{lvhd}}$	600	—	—	ps	
Vertical Active Display Term	Frame Rate	$F_{\text{r5}}$	47	50	53	Hz	(6)
		$F_{\text{r6}}$	57	60	63	Hz	
	Total	$T_{\text{v}}$	778	806	888	Th	$T_{\text{v}}=T_{\text{vd}}+T_{\text{vb}}$
	Display	$T_{\text{vd}}$	768	768	768	Th	—
	Blank	$T_{\text{vb}}$	10	38	120	Th	—
Horizontal Active Display Term	Total	$T_{\text{h}}$	1442	1560	1936	Tc	$T_{\text{h}}=T_{\text{hd}}+T_{\text{hb}}$
	Display	$T_{\text{hd}}$	1366	1366	1366	Tc	—
	Blank	$T_{\text{hb}}$	76	194	570	Tc	—

Note (1) Please make sure the range of pixel clock has follow the below equation :

$$F_{\text{clkin(max)}} \geq F_{\text{r6}} \times T_{\text{v}} \times T_{\text{h}}$$

$$F_{\text{r5}} \times T_{\text{v}} \times T_{\text{h}} \geq F_{\text{clkin(min)}}$$

Note (2) This module is operated in DE only mode and please follow the input signal timing diagram below :



**INPUT SIGNAL TIMING DIAGRAM**

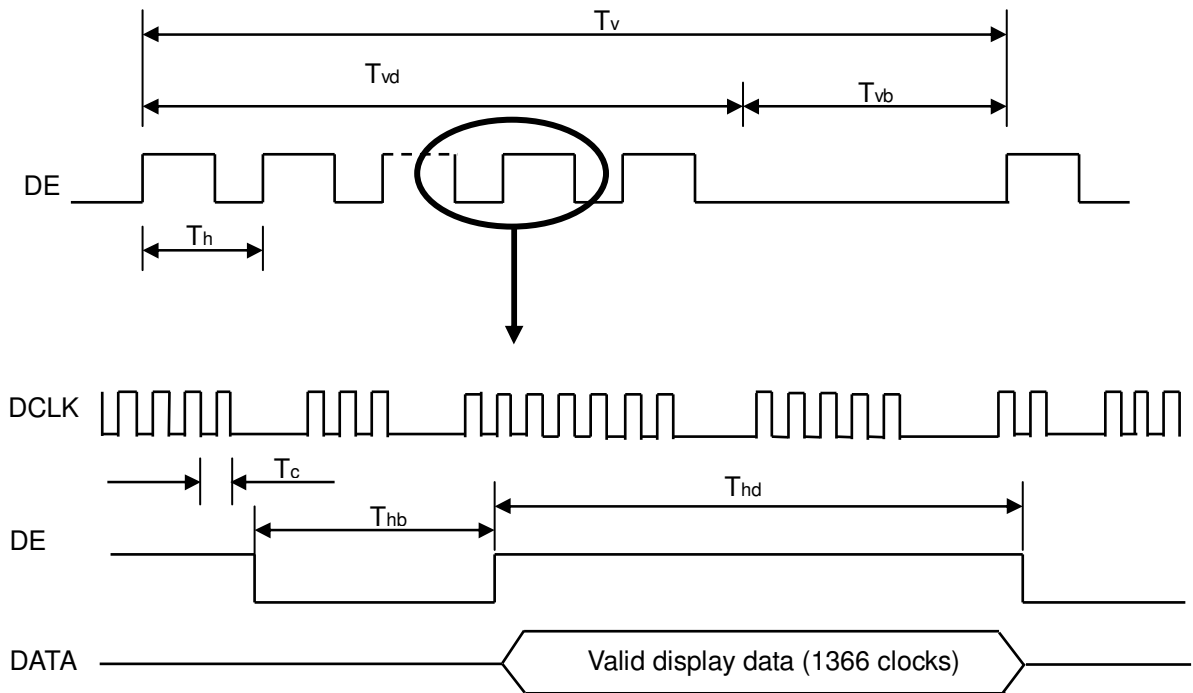

Note (3) The input clock cycle-to-cycle jitter is defined as below figures.  $Trcl = |T_1 - T_1|$

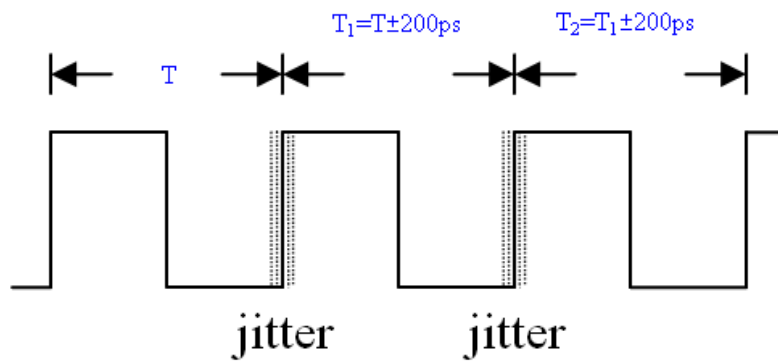

Note (4) The SSCG (Spread spectrum clock generator) is defined as below figures.

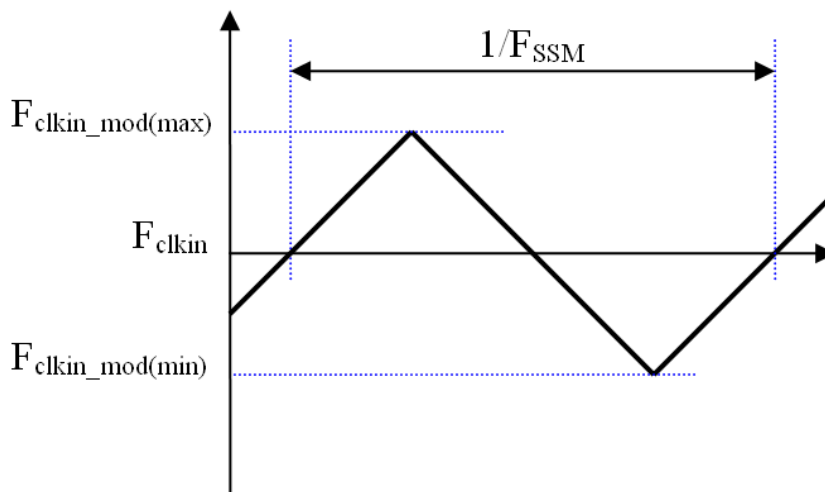

Note (5) The LVDS timing diagram and setup/hold time is defined and showing as the following figures.

**LVDS RECEIVER INTERFACE TIMING DIAGRAM**

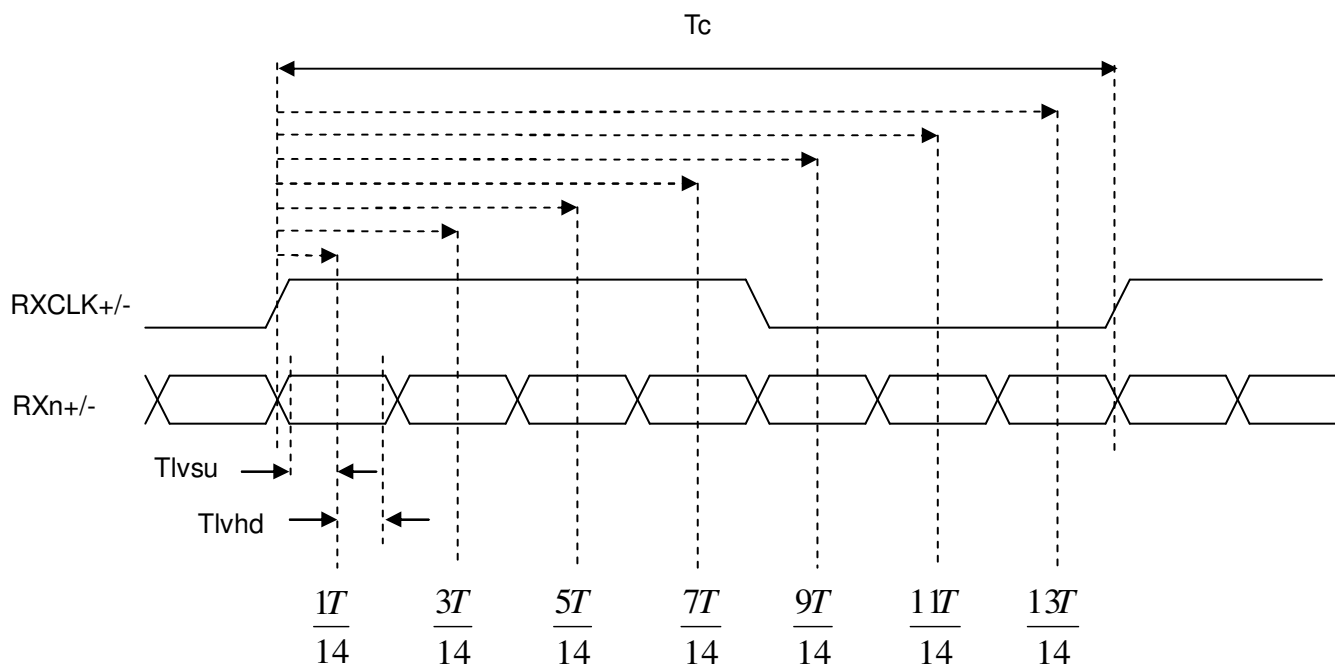

Note (6) : (ODSEL) = H/L or open for 50/60Hz frame rate. Please refer to 5.1 for detail information

## 6.2 POWER ON/OFF SEQUENCE

( $T_a = 25 \pm 2^\circ\text{C}$ )

To prevent a latch-up or DC operation of LCD module, the power on/off sequence should be as the diagram below.

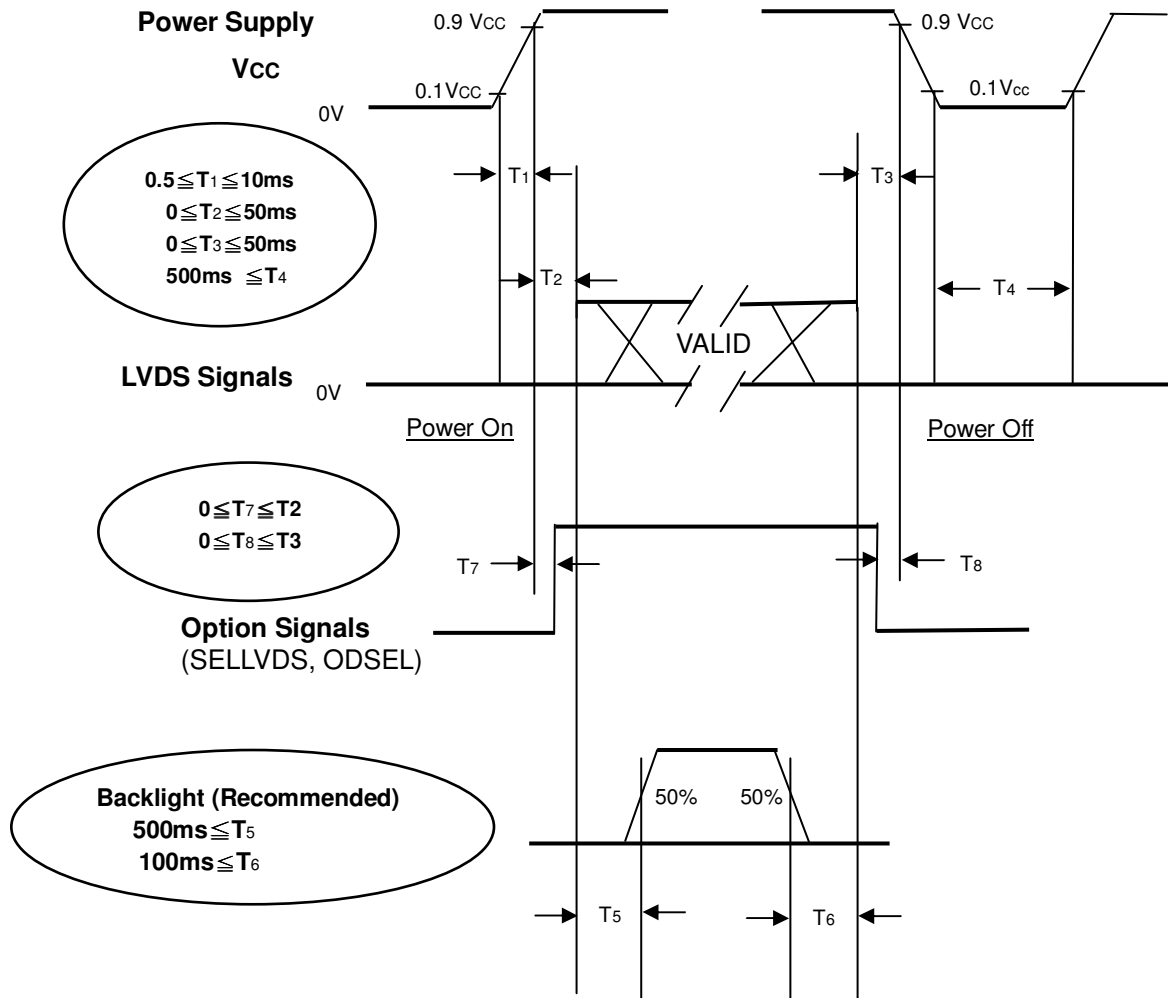

**Power ON/OFF Sequence**

Note (1) The supply voltage of the external system for the module input should follow the definition of Vcc.

Note (2) Apply the lamp voltage within the LCD operation range. When the backlight turns on before the LCD operation or the LCD turns off before the backlight turns off, the display may momentarily become abnormal screen.

Note (3) In case of Vcc is in off level, please keep the level of input signals on the low or high impedance. If  $T_2 < 0$ , that maybe cause electrical overstress failures.

Note (4) T4 should be measured after the module has been fully discharged between power off and on period.

Note (5) Interface signal shall not be kept at high impedance when the power is on.

## 7. OPTICAL CHARACTERISTICS

### 7.1 TEST CONDITIONS

Item	Symbol	Value	Unit
Ambient Temperature	Ta	25±2	°C
Ambient Humidity	Ha	50±10	%RH
Supply Voltage	V <sub>CC</sub>	5.0	V
Input Signal	According to typical value in "3. ELECTRICAL CHARACTERISTICS"		
Inverter Current	I <sub>L</sub>	10.5±0.5	mA
Inverter Driving Frequency	F <sub>L</sub>	63±3	KHz

### 7.2 OPTICAL SPECIFICATIONS

The relative measurement methods of optical characteristics are shown as below. The following items should be measured under the test conditions described in 7.1 and stable environment shown in Note (5).

Item	Symbol	Condition	Min.	Typ.	Max.	Unit	Note	
Color Chromaticity	Red	Rx	Viewing angle at normal direction With CMO module	Typ.-0.03	Typ+0.03		(1),(5)	
		Ry						
	Green	Gx						
		Gy						
	Blue	Bx						
		By						
	White	Wx						
		Wy						
Center Transmittance	T%	$\theta_x=0^\circ, \theta_y=0^\circ$ With CMO Module	-	5.8		%	(1), (7)	
Contrast Ratio	CR	$\theta_x=0^\circ, \theta_y=0^\circ$ With CMO Module	2000	3000		-	(1), (3)	
Response Time	Gray to gray average	$\theta_x=0^\circ, \theta_y=0^\circ$ With CMO Module@60Hz	-	6.5	12	ms	(4)	
White Variation	$\delta W$	$\theta_x=0^\circ, \theta_y=0^\circ$ With CMO Module			1.5	-	(1), (6)	
Viewing Angle	Horizontal	$\theta_{x+}$	CR≥20 With CMO Module	80	88	-	Deg.	(1), (2)
		$\theta_{x-}$		80	88	-		
	Vertical	$\theta_{y+}$		80	88	-		
		$\theta_{y-}$		80	88	-		

Note (1) Light source is CMO's BLU(V315B6-L01) and driving voltages are based on suitable gamma voltages.

The calculated method is as following:

1. Measure module's and backlight's spectrum. White and R, G, B are with signal input.
2. Calculate cell's spectrum.

Note (2) Definition of Viewing Angle ( $\theta_x, \theta_y$ ):

Viewing angles are measured by Autronic Conoscope Cono-80

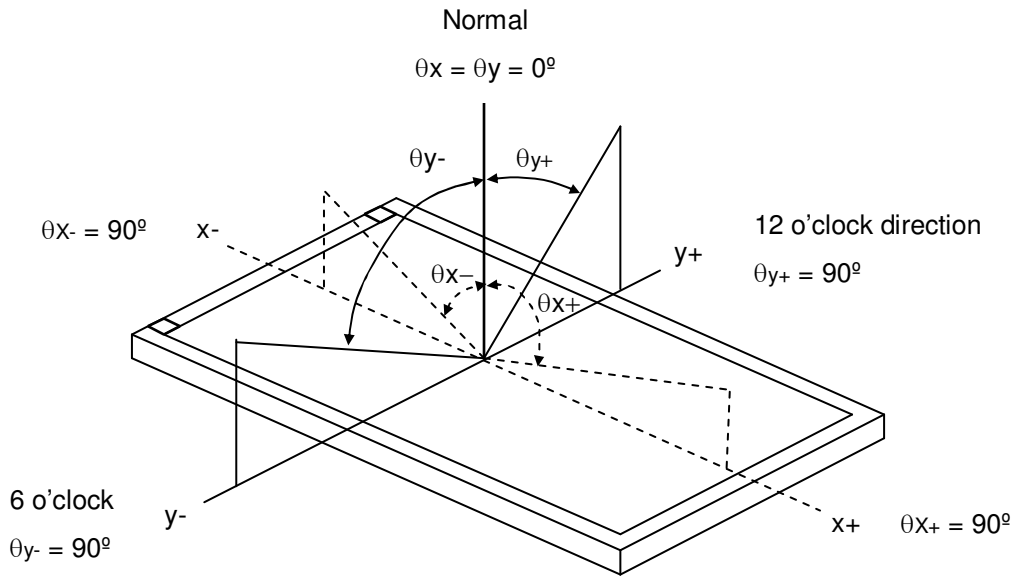

Note (3) Definition of Contrast Ratio (CR):

The contrast ratio can be calculated by the following expression.

$$\text{Contrast Ratio (CR)} = L_{255} / L_0$$

L<sub>255</sub>: Luminance of gray level 255

L<sub>0</sub>: Luminance of gray level 0

CR = CR (X), where CR (X) is corresponding to the Contrast Ratio of the point X at the figure in Note (6).

Note (4) Definition of Gray-to-Gray Switching Time:

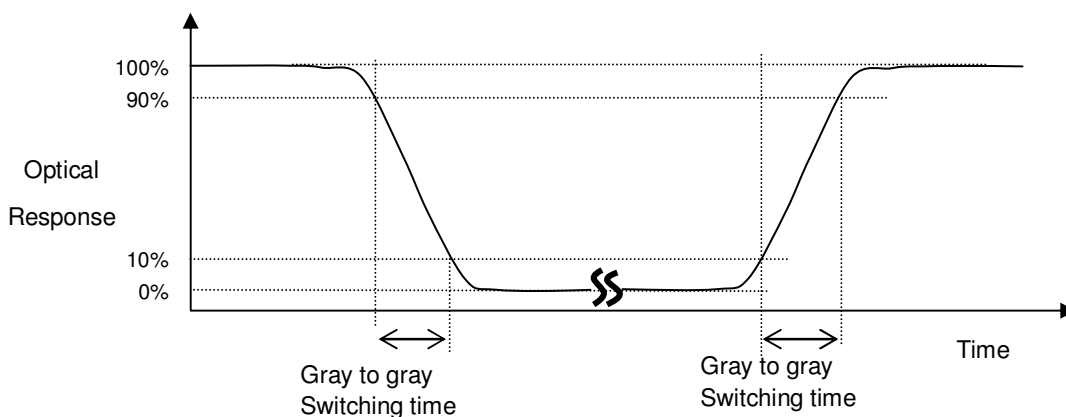

The driving signal means the signal of gray level 0, 123, 168, 202, 230, 255. Gray to gray average time means the average switching time of gray level 0, 123, 168, 202, 230, 255 to each other.

Note (5) Measurement Setup:

The LCD module should be stabilized at given temperature for 60 minutes to avoid abrupt

temperature change during measuring. In order to stabilize the luminance, the measurement should be executed after lighting Backlight for 60 minutes in a windless room.

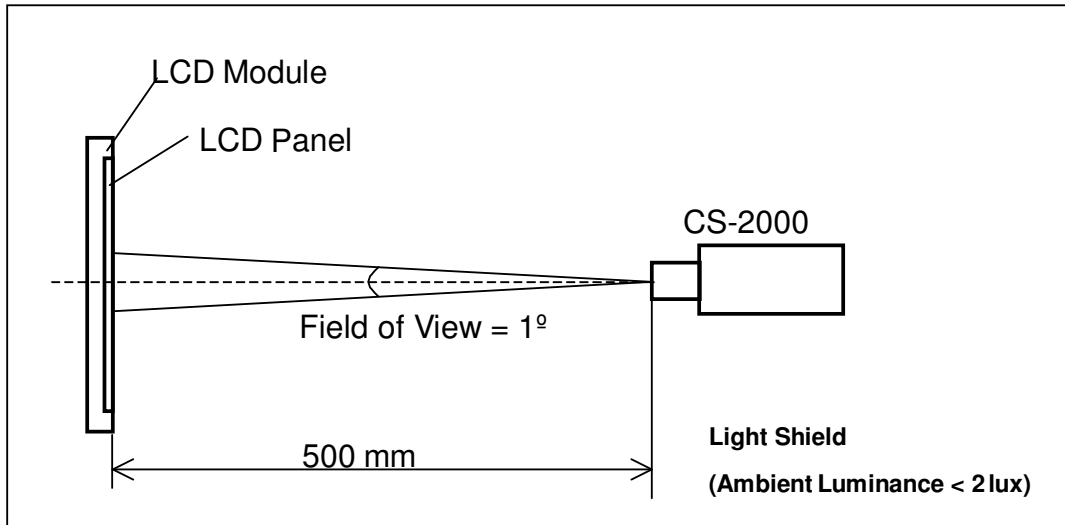

Note (6) Definition of White Variation ( $\delta W$ ):

Measure the luminance of gray level 255 at 5 points

$$\delta W = \text{Maximum} [L (1), L (2), L (3), L (4), L (5)] / \text{Minimum} [L (1), L (2), L (3), L (4), L (5)]$$

where L (X) is corresponding to the luminance of the point X at the figure below.

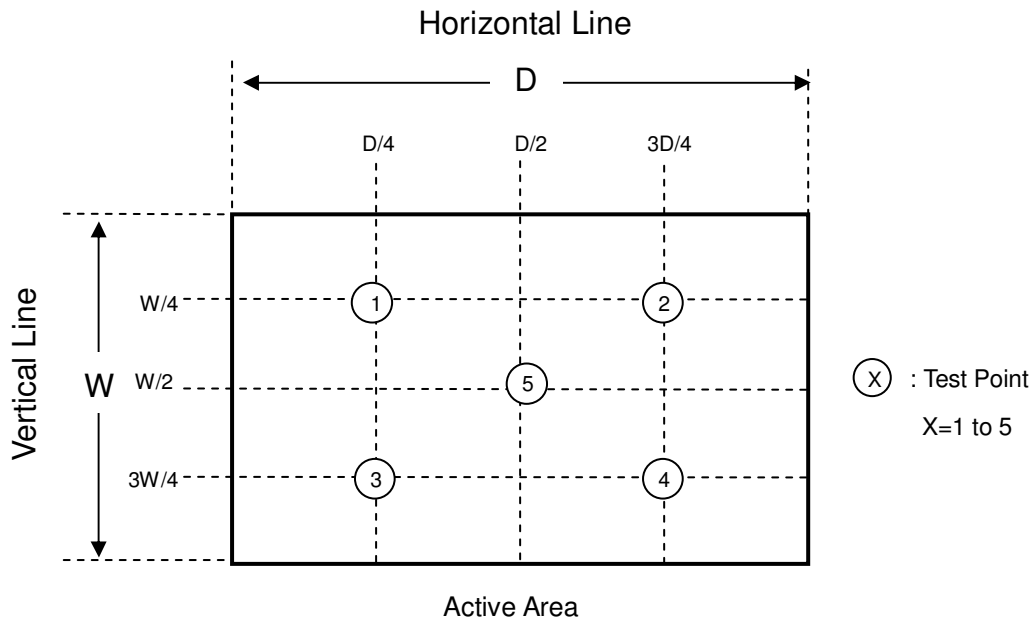

Note (7) Definition of Transmittance (T%):

Module is without signal input.

$$\text{Transmittance} = \frac{\text{Luminance of LCD module}}{\text{Luminance of backlight}} * 100\%$$

## 8. DEFINITION OF LABELS

### 8.1 OPEN CELL LABEL

The barcode nameplate is pasted on each open cell as illustration for CMO internal control.

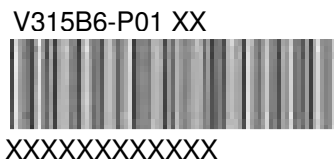

### 8.2 CARTON LABEL

The barcode nameplate is pasted on each box as illustration, and its definitions are as following explanation.

P.O. NO. \_\_\_\_\_

Parts ID. \_\_\_\_\_

Model Name  V315B6-P01

Carton ID.  Quantities  21

XXXXXXXXXXXXXX

Made In China

- (a) Model Name: V315B6- P01
- (b) Carton ID: CMO internal control
- (c) Quantities: 21

**9. PACKAGING**

**9.1 PACKING SPECIFICATIONS**

- (1) 21 LCD TV Panels / 1 Box
- (2) Box dimensions : 970 (L) X 640 (W) X 319 (H)
- (3) Weight : approximately 38Kg ( 21 panels per box)

**9.2 PACKING METHOD**

Figures 9-1 and 9-2 are the packing method

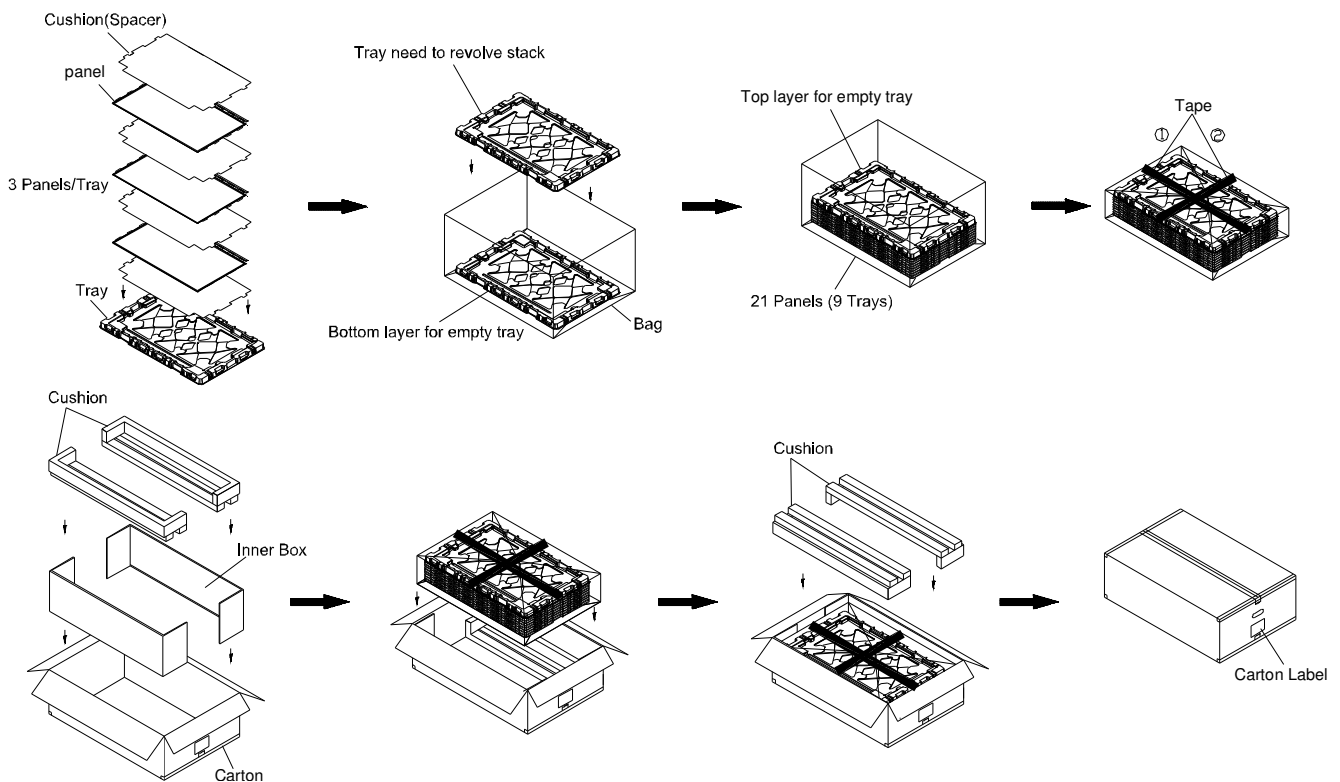

Figure.9-1 packing method



### Sea & Land Transportation

### Air Transportation

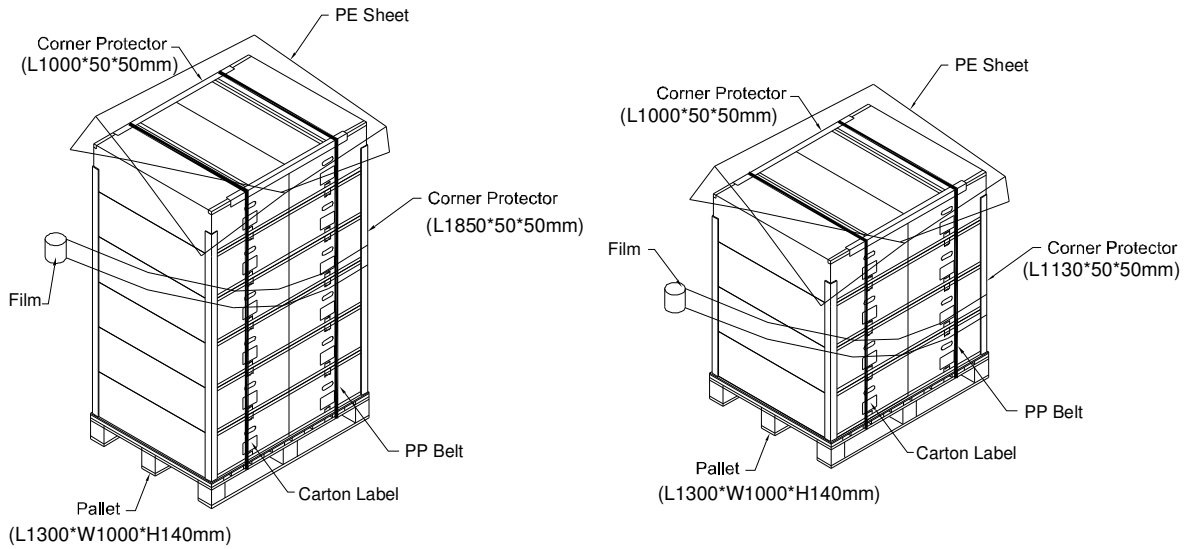

Figure.9-2 packing method

## 10. PRECAUTIONS

### 10.1 ASSEMBLY AND HANDLING PRECAUTIONS

- (1) Do not apply rough force such as bending or twisting to the product during assembly.
- (2) To assemble backlight or install module into user's system can be only in clean working areas. The dust and oil may cause electrical short or worsen the polarizer.
- (3) It's not permitted to have pressure or impulse on the module because the LCD panel will be damaged.
- (4) Always follow the correct power sequence when the product is connecting and operating. This can prevent damage to the CMOS LSI chips during latch-up.
- (5) Do not pull the I/F connector in or out while the module is operating.
- (6) Use a soft dry cloth without chemicals for cleaning, because the surface of polarizer is very soft and easily scratched.
- (7) It is dangerous that moisture come into or contacted the product, because moisture may damage the product when it is operating.
- (8) High temperature or humidity may reduce the performance of module. Please store this product within the specified storage conditions.
- (9) When ambient temperature is lower than 10°C may reduce the display quality. For example, the response time will become slowly.

### 10.2 SAFETY PRECAUTIONS

- (1) If the liquid crystal material leaks from the panel, it should be kept away from the eyes or mouth. In case of contact with hands, skin or clothes, it has to be washed away thoroughly with soap.
- (2) After the product's end of life, it is not harmful in case of normal operation and storage.

