

# HITACHI

KAOHSIUNG HITACHI ELECTRONICS CO., LTD.

FOR MESSRS:

DATE: Jun. 10<sup>th</sup> 2010

## CUSTOMER'S ACCEPTANCE SPECIFICATIONS

### TX26D13VM2BAA

#### Contents

No.	ITEM	SHEET No.	PAGE
1	COVER	7B64PS 2701-TX26D13VM2BAA-1	1-1/1
2	RECORD OF REVISION	7B64PS 2702-TX26D13VM2BAA-1	2-1/1
3	GENERAL DATA	7B64PS 2703-TX26D13VM2BAA-1	3-1/1
4	ABSOLUTE MAXIMUM RATINGS	7B64PS 2704-TX26D13VM2BAA-1	4-1/1
5	ELECTRICAL CHARACTERISTICS	7B64PS 2705-TX26D13VM2BAA-1	5-1/2~2/2
6	OPTICAL CHARACTERISTICS	7B64PS 2706-TX26D13VM2BAA-1	6-1/2~2/2
7	BLOCK DIAGRAM	7B64PS 2707-TX26D13VM2BAA-1	7-1/1
8	RELIABILITY TESTS	7B64PS 2708-TX26D13VM2BAA-1	8-1/1
9	LCD INTERFACE	7B64PS 2709-TX26D13VM2BAA-1	9-1/5~5/5
10	OUTLINE DIMENSIONS	7B64PS 2710-TX26D13VM2BAA-1	10-1/2~2/2
11	APPEARANCE STANDARD	7B64PS 2711-TX26D13VM2BAA-1	11-1/3~3/3
12	PRECAUTIONS	7B64PS 2712-TX26D13VM2BAA-1	12-1/2~2/2
13	DESIGNATION of LOT MARK	7B64PS 2713-TX26D13VM2BAA-1	13-1/1

ACCEPTED BY: \_\_\_\_\_

PROPOSED BY: Ken Chen

## 2. RECORD OF REVISION

DATE	SHEET No.	SUMMARY

### 3. GENERAL DATA

#### 3.1 DISPLAY FEATURES

This module is a 10.2" HSVGA TFT module. The pixel format is vertical stripe and sub pixels are arranged as R(red), G(green), B(blue) sequentially. This display is RoHS compliant, COG (chip on glass) technology and LED backlight are applied on this display.

Part Name	TX26D13VM2BAA
Module Dimensions	260.2(W) mm x 96.2(H) mm x 10.55(D) mm typ.
LCD Active Area	246.0(W) mm x 78.72(H) mm
Dot Pitch	0.125(W) mm x 3(R, G, B)(W) x 0.375(H) mm
Resolution	800 x 3(RGB)(W) x 256(H) dots
Color Pixel Arrangement	R, G, B Vertical stripe
LCD Type	Transmissive Color TFT; Normally White
Display Type	Active Matrix
Number of Colors	262k Colors
Backlight	LED (Life-time 40khr)
Weight	240 g (typ.)
Interface	C-MOS; 18-bit RGB; 40 pins
Power Supply Voltage	3.3V for LCD
Power Consumption	0.56 W for LCD ; 1.87W for Backlight
Viewing Direction	12 O'clock (Without image inversion and least brightness change) 6 O'clock (Contrast peak located at)

## 4. ABSOLUTE MAXIMUM RATINGS

Item	Symbol	Min.	Max.	Unit	Remarks	
Supply Voltage	VDD	0	4.0	V	-	
Input Voltage of Logic	VI	-0.3	VDD+0.3	V	Note 1	
Operating Temperature	Top	-20	70	°C	Note 2	
Storage Temperature	Tst	-30	80	°C	Note 2	
LED Unit	For ward Current	IF	-	35	mA	-
	Reverse Voltage	VR	-	5	V	-

Note 1: The rating is defined for the signal voltages of the interface such as DTMG, DCLK and RGB data bus.

Note 2: The maximum rating is defined as above based on the temperature on the panel surface, which might be different from ambient temperature after assembling the panel into the application. Moreover, some temperature-related phenomenon as below needed to be noticed:

- Background color, contrast and response time would be different in temperatures other than 25°C.
- Operating under low temperature will shorten LED lifetime.

# 5. ELECTRICAL CHARACTERISTICS

## 5.1 LCD CHARACTERISTICS

$T_a = 25\text{ }^\circ\text{C}$ ,  $V_{SS} = 0\text{V}$

Item	Symbol	Condition	Min.	Typ.	Max.	Unit	Remarks
Power Supply Voltage	VDD	-	3.0	3.3	3.6	V	-
Input Voltage of Logic	VI	"H" level	2.0	-	VDD	V	Note 1
		"L" level	VSS	-	0.8		
Power Supply Current	IDD	VDD-VSS=3.3V	-	137	165	mA	Note 2,3
Vsync Frequency	$f_v$	-	-	60	75	Hz	-
Hsync Frequency	$f_H$	-	-	18.9	25	KHz	-
DCLK Frequency	$f_{CLK}$	-	-	20	27.2	MHz	-

Note 1: The rating is defined for the signal voltages of the interface such as DTMG, DCLK, RGB data and timing signal.

Note 2:  $f_v=60\text{Hz}$  ,  $f_{CLK}=33.3\text{MHz}$  ,  $V_{DD}=3.3\text{V}$ .

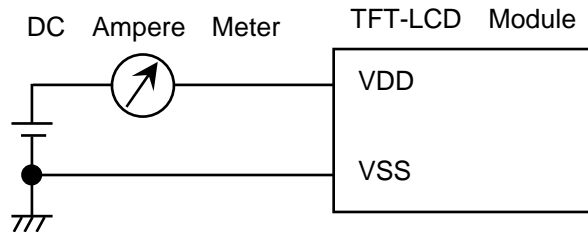

Typical value is measured by displaying black raster pattern. Maximum value is measured by displaying Vertical-stripe pattern of 2 pixel pitch.

Note 3: 0.4A fuse is applied in the module for IDD. For display activation and protection purpose, power supply is recommended larger than to 1.0A start the display and break fuse once any short circuit occurred.

## 5.2 BACKLIGHT CHARACTERISTICS

$T_a = 25^\circ C$

Item	Symbol	Condition	Min.	Typ.	Max.	Unit	Remarks
LED Input Voltage	VLED	Backlight Unit	11.5	12.0	12.5	V	-
LED Forward Current	ILED	Backlight Unit	-	156	165	mA	-
LED Lifetime	-	156 mA	-	40K	-	hrs	Note 1

Note 1: Fig. 5.1 shows the LED backlight circuit. The circuit has 39 LEDs in total and R is  $255\Omega$ .

Note 2: The estimated lifetime is specified as the time to reduce 50% brightness by applying 156 mA at  $25^\circ C$ .

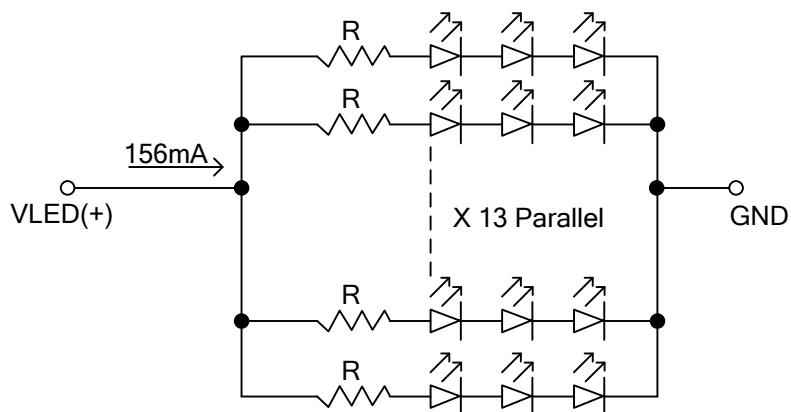

Fig 5.1

## 6. OPTICAL CHARACTERISTICS

The optical characteristics are measured based on the conditions as below:

- Supplying the signals and voltages defined in the section of electrical characteristics.
- The backlight unit needs to be turned on for 30 minutes.
- The ambient temperature is 25 °C.
- In the dark room around 500~1000 lx, the equipment has been set for the measurements as shown in Fig 6.1.

$$T_a = 25 \pm 3 \text{ } ^\circ\text{C}, VDD = 3.3 \text{ V}, f_v = 60 \text{ Hz}$$

Item	Symbol	Condition	Min.	Typ.	Max.	Unit	Remarks	
Brightness of White	-	$\phi = 0^\circ, \theta = 0^\circ$ ILED=156mA	300	350	-	cd/m <sup>2</sup>	Note 1	
Brightness Uniformity	-		75	-	-	%	Note 2	
Contrast Ratio	CR		200	500	-	-	Note 3	
Response Time	Up	$\phi = 0^\circ, \theta = 0^\circ$	-	25	40	ms	Note 4	
	Down		-	15	30	ms		
NTSC Ratio	-	$\phi = 0^\circ, \theta = 0^\circ$	-	60	-	%	-	
Viewing Angle	$\theta_x$	$\phi = 0^\circ, CR \geq 10$	50	-	-	Degree	Note 5	
	$\theta_{x'}$	$\phi = 180^\circ, CR \geq 10$	50	-	-			
	$\theta_y$	$\phi = 90^\circ, CR \geq 10$	45	-	-			
	$\theta_{y'}$	$\phi = 270^\circ, CR \geq 10$	50	-	-			
Color Chromaticity	Red	X	$\phi = 0^\circ, \theta = 0^\circ$	0.57	0.62	0.67	-	Note 6
		Y		0.31	0.36	0.41		
	Green	X		0.29	0.34	0.39		
		Y		0.53	0.58	0.63		
	Blue	X		0.10	0.15	0.20		
		Y		0.04	0.09	0.14		
	White	X		0.27	0.32	0.37		
		Y		0.27	0.32	0.37		

Note 1: The brightness is measured from the center point of the panel, P5 in Fig. 6.2, for the typical value.

Note 2: The brightness uniformity is calculated by the equation as below:

$$\text{Brightness uniformity} = \frac{\text{Min. Brightness}}{\text{Max. Brightness}} \times 100\%$$

, which is based on the brightness values of the 9 points measured by BM-5 as shown in Fig. 6.2.

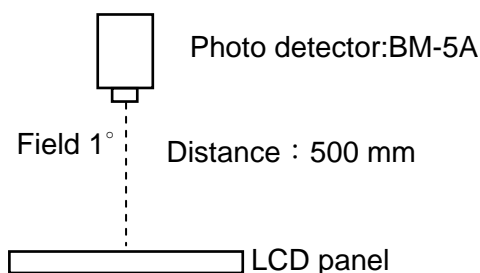

Fig. 6.1

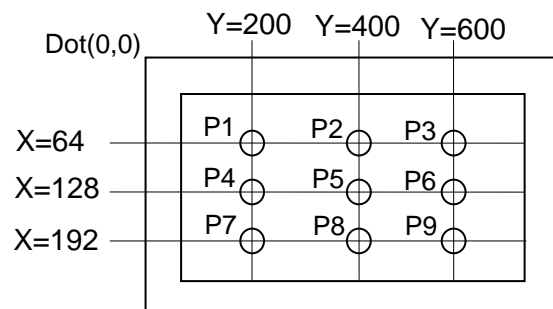

Fig. 6.2

Note 3: The Contrast ratio is measured from the center point of the panel, P5, and defined as the following equation:

$$CR = \frac{\text{Brightness of White}}{\text{Brightness of Black}}$$

Note 4: The definition of response time is shown in Fig. 6.3. The rising time is the period from 90% brightness to 10% brightness when the data is from white to black. Oppositely, Falling time is the period from 10% brightness rising to 90% brightness.

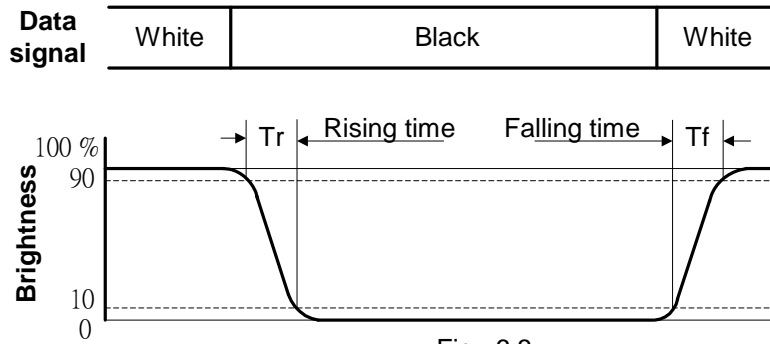

Fig . 6.3

Note 5: The definition of viewing angle is shown in Fig. 6.4. Angle  $\phi$  is used to represent viewing directions, for instance,  $\phi = 270^\circ$  means 6 o'clock, and  $\phi = 0^\circ$  means 3 o'clock. Moreover, angle  $\theta$  is used to represent viewing angles from axis Z toward plane XY.

The viewing direction of this display is 12 o'clock, which means that a photograph with gray scale would not be reversed in color and the brightness change would be less from this direction. However, the best contrast peak would be located at 6 o'clock.

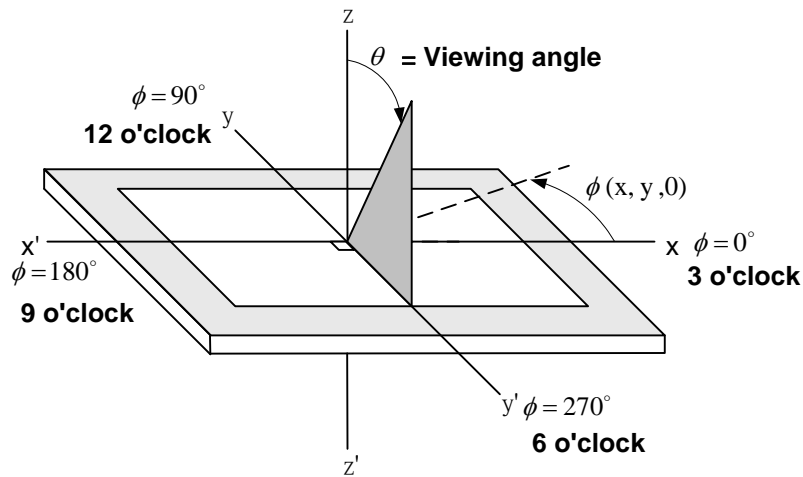

Fig. 6.4

Note 6: The color chromaticity is measured from the center point of the panel, P5, as shown in Fig. 6.2.



# 7 BLOCK DIAGRAM

## 7.1 TFT TFT LIQUID CRYSTAL DISPLAY MODULE

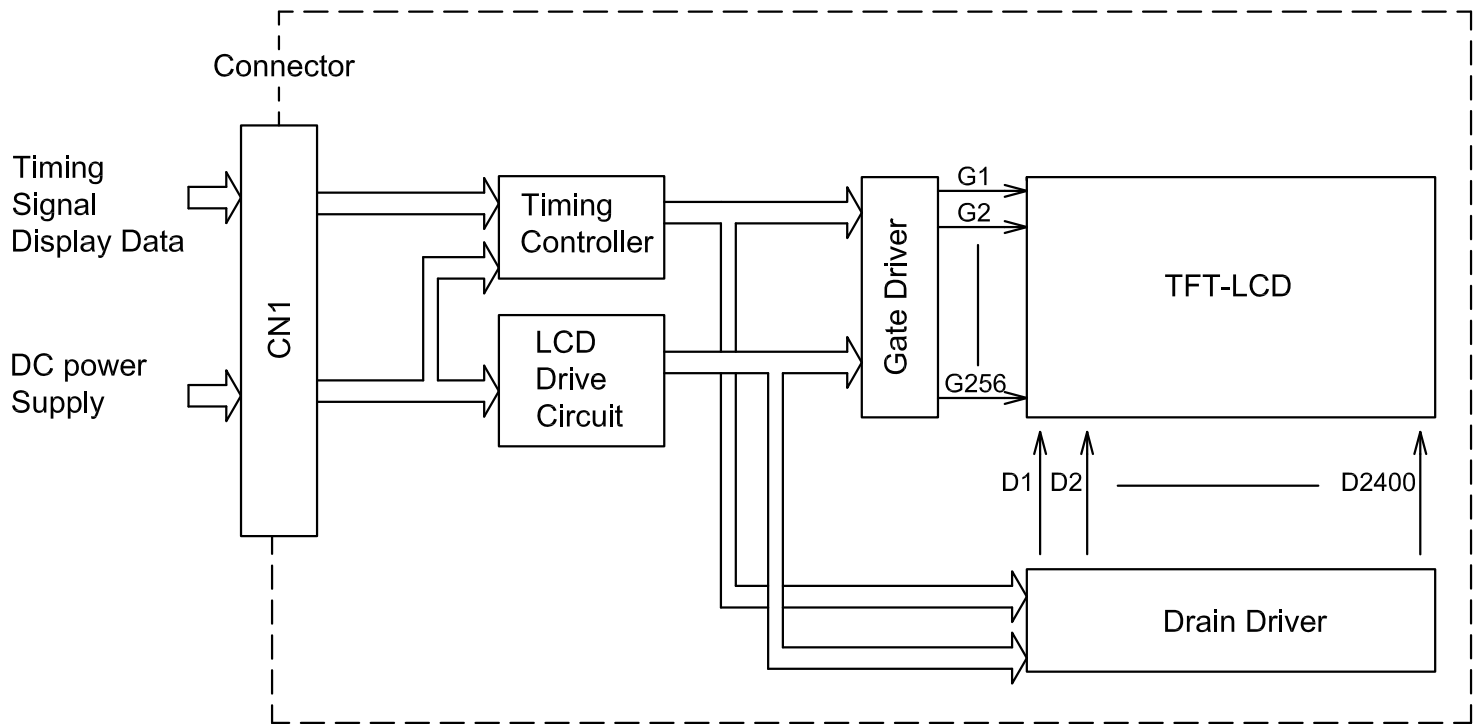

## 7.2 BACK-LIGHT UNIT

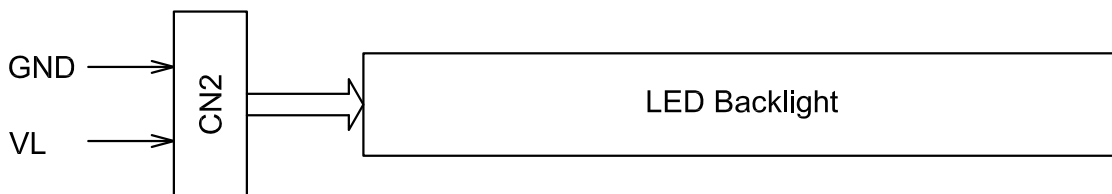

Note : Pin1 (VL) : Pink  
Pin3 (GND) : White

## 8. RELIABILITY TESTS

Test Item	Condition	
High Temperature	1) Operating 2) 70 °C	240 hrs
Low Temperature	1) Operating 2) -20 °C	240 hrs
High Temperature	1) Storage 2) 80 °C	240 hrs
Low Temperature	1) Storage 2) -30 °C	240 hrs
Heat Cycle	1) Operating 2) -20 °C ~70 °C 3) 3hrs~1hr~3hrs	240 hrs
Thermal Shock	1) Non-Operating 2) -35 °C ↔ 85 °C 3) 0.5 hr ↔ 0.5 hr	240 hrs
High Temperature & Humidity	1) Operating 2) 40 °C & 85%RH 3) Without condensation 4) Note 4	240 hrs
Vibration	1) Non-Operating 2) 20~50 Hz 3) 2G 4) X, Y, and Z directions	1 hr for each direction
Mechanical Shock	1) Non-Operating 2) 3 ms 3) 50G 4) ±X, ±Y and ±Z directions	Once for each direction
ESD	1) Operating 2) Tip: 200 pF, 250 Ω 3) Air discharge for glass: ± 8KV 4) Contact discharge for metal frame: ± 8KV (Note 3)	1) Glass: 9 points 2) Metal frame: 8 points

Note 1: Display functionalities are inspected under the conditions defined in the specification after the reliability tests.

Note 2: The display is not guaranteed for use in corrosive gas environments.

Note 3: All pins of LCD interface(CN1) have been tested by ± 100V contact discharge of ESD under non-operating condition, with 200pF, 250Ω at 25 °C, 70%RH environment.

Note 4: Under the condition of high temperature & humidity, if the temperature is higher than 40 °C, the humidity needs to be reduced as Fig. 8.1 shown.

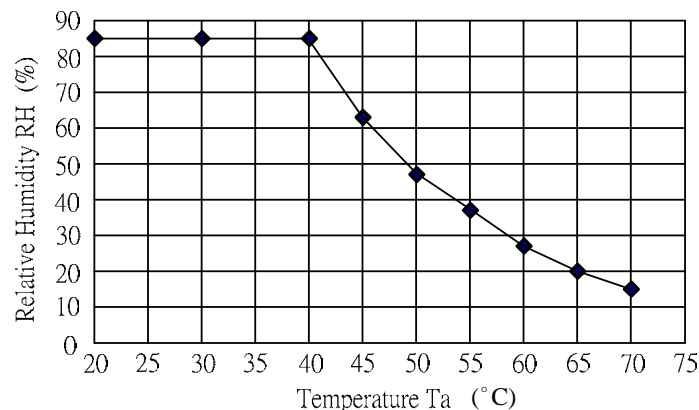

Fig. 8.1

## 9. LCD INTERFACE

### 9.1 INTERFACE PIN CONNECTIONS

The display interface connector is FA5B040HP1R3000 made by JAE (Thickness:  $0.3 \pm 0.05\text{mm}$ ; Pitch:  $0.5 \pm 0.05\text{mm}$ ) and more details of the connector are shown in the section of outline dimension.

Pin assignment of LCD interface is as below:

CN1 《JAE ; FA5B040HP1R3000》

Pin No.	Symbol	Description	Remarks
1	VSS	GND (0V)	Note 1
2	VSS		
3	DCLK	Dot Clock	
4	VSS	GND (0V)	Note 1
5	VSS		
6	(IC)		Note 2
7	R0	Red Data	
8	R1		
9	R2		
10	VSS	GND (0V)	Note 1
11	R3	Red Data	
12	R4		
13	R5		
14	VSS	GND (0V)	Note 1
15	G0	Green Data	
16	G1		
17	G2		
18	VSS	GND (0V)	Note 1
19	G3	Green Data	
20	G4		

Pin No.	Symbol	Description	Remarks
21	G5	Green Data	
22	VSS	GND (0V)	Note 1
23	B0	Blue Data	
24	B1		
25	B2		
26	VSS	GND (0V)	Note 1
27	B3	Blue Data	
28	B4		
29	B5		
30	VSS	GND (0V)	Note 1
31	(IC)		Note 2
32	VSS	GND (0V)	Note 1
33	NC	No Connection	Note 3
34	VSS	GND (0V)	Note 1
35	DTMG	Display Timing	
36	NC	No Connection	Note 3
37	VDD	Power Supply	Note 4
38	VDD	(typ.+3.3V)	
39	VDD		
40	VDD		

Note 1: All VSS pins shall be grounded. Metal bezel is internally connected to VSS.

Note 2: Keep open electrically. HITACHI test use only.

Note 3: Unconnected to the module.

Note 4: All VDD pins shall be connected to +3.3V(Typ.)

### 9.2 BACK-LIGHT UNIT

CN2 《JST ; BHR-03VS-1》

Pin No.	Symbol	Description
1	VLED+	Power Supply
2	NC	No Connection
3	VLED-	GND (0V)

### 9.3 TIMING CHART

Data: Latched at fall edge of DCLK

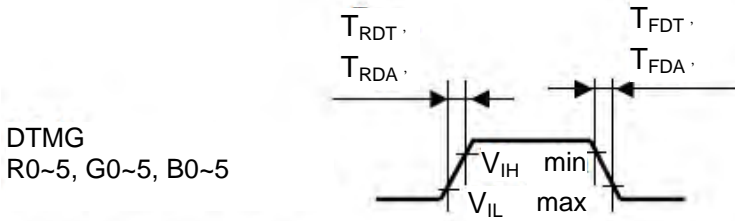

#### DCLK Data Timing

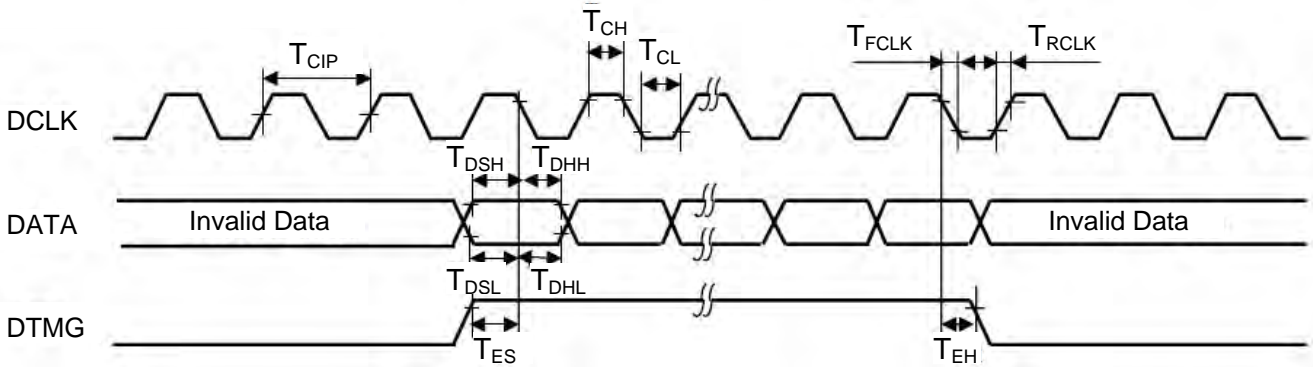

#### Vsync Timing

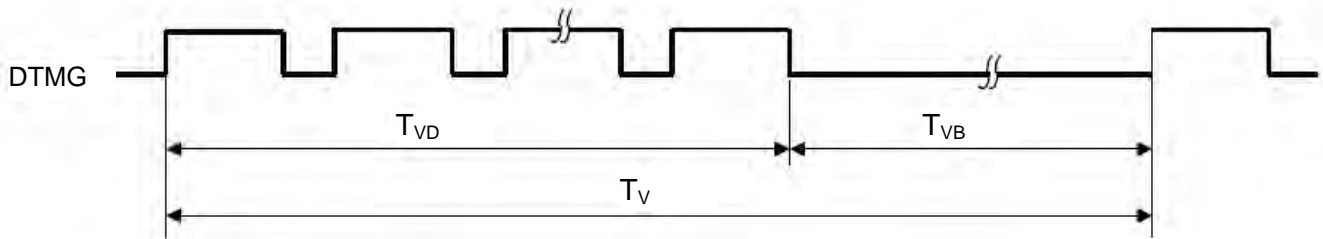

#### Hsync Timing

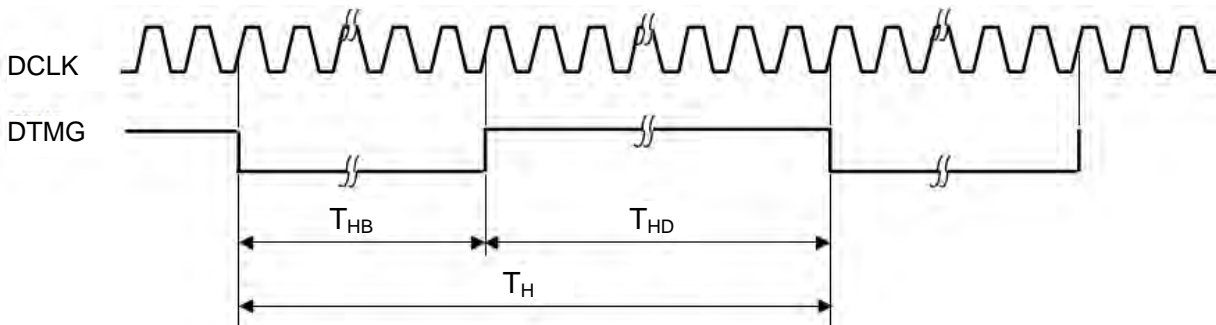

The DTMG signal for this module is defined as above-mentioned timings for Vsync and Hsync. This module synchronizes with only DTMG and don't require inputting Vsync and Hsync signals. During blanking period, DTMG should be "Low" level.

## 9.4 INTERFACE TIMING SPECIFICATIONS

### 9.4.1 HALF-SVGA INPUT MODE

Item		Symbol	Min.	Typ.	Max.	Unit	Remarks
DCLK	Cycle time	$1/T_{CIP}$	14.6	20	27.2	MHz	-
	Low level Width	$T_{CL}$	8	-	-	ns	
	High level Width	$T_{CH}$	8	-	-	ns	
	Duty	D	0.45	0.5	0.55	-	$D=T_{CL}/T_{CIP}$
	Rise time	$T_{RCLK}$	-	-	4	ns	-
	Fall time	$T_{FCLK}$	-	-	4		
Data	Set up time	$T_{DSH}/T_{DSL}$	5	-	-	ns	-
	Hold time	$T_{DHH}/T_{DHL}$	5	-	-		
	Rise time	$T_{RDA}$	-	-	5	ns	
	Fall time	$T_{FDA}$	-	-	5		
DTMG	Set up time	$T_{ES}$	5	-	-	ns	-
	Hold time	$T_{HE}$	5	-	-		
	Vertical cycle	$T_V$	258	316	416	TH	-
	Vertical valid width	$T_{VD}$	256				
	Vertical back porch	$T_{VB}$	2	60	160		
	Horizontal cycle	$T_H$	944	1056	1088	DCLK	-
	Horizontal valid width	$T_{HD}$	800				
	Horizontal back porch	$T_{HB}$	144	256	288		
	Rise time	$T_{RDT}$	-	-	5	ns	-
Fall time	$T_{FDT}$	-	-	5			

## 9.5 POWER SEQUENCE

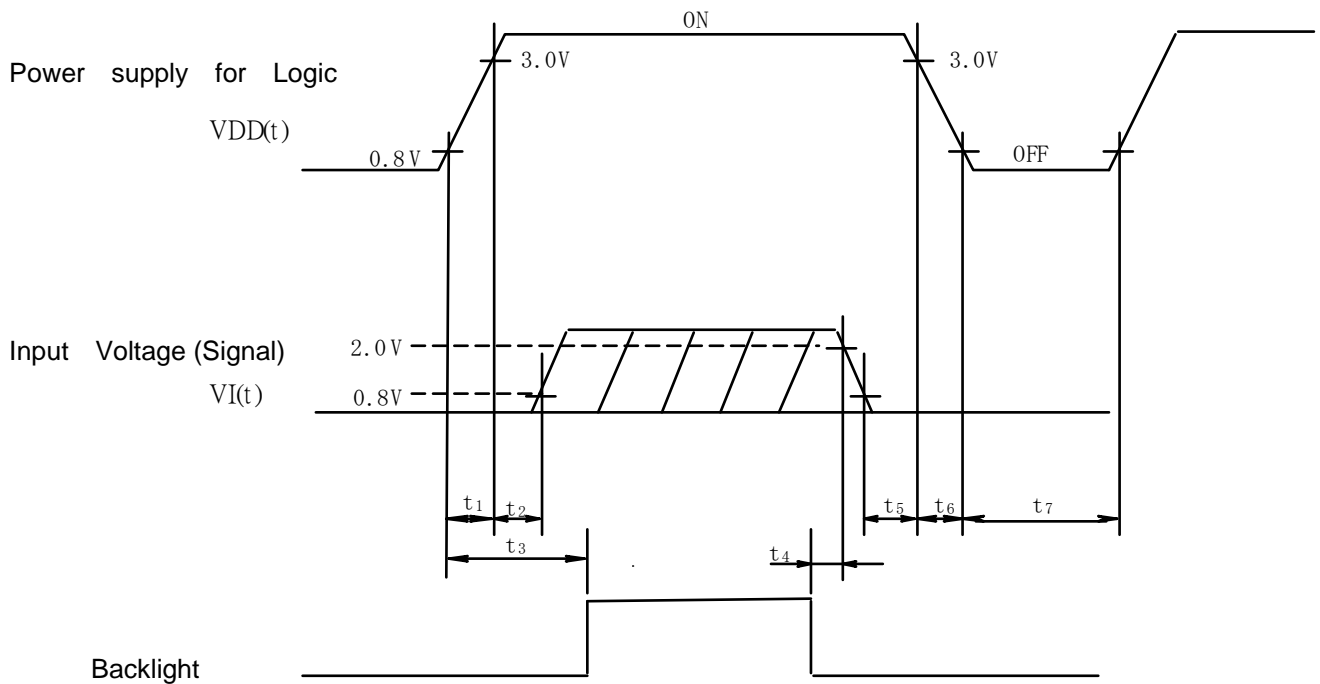

### POWER\_ON

$$t_1 \leq 15\text{ms}$$

$$0\text{ms} < t_2 \leq 45\text{ms}$$

$$0.1\text{s} \leq t_3$$

### POWER\_OFF

$$5\text{ms} \leq t_4$$

$$0\text{ms} \leq t_5 \leq 45\text{ms}$$

$$0\text{ms} \leq t_6 \leq 20\text{ms}$$

$$0.4\text{s} \leq t_7$$

Note 1: Set  $0\text{V} \leq VI(t) \leq VDD(t)$ .

Here,  $VI(t)$ ,  $VDD(t)$  indicate the transitional state of  $VI$ ,  $VDD$  when power supply is turned ON or OFF.

Note 2: Do not keep interface signal high-impedance when power on.

## 9.6 DATA INPUT for DISPLAY COLOR

Color	Input	Red Data						Green Data						Blue Data					
		R5	R4	R3	R2	R1	R0	G5	G4	G3	G2	G1	G0	B5	B4	B3	B2	B1	B0
		MSB			LSB			MSB			LSB			MSB			LSB		
Basic Color	Black	0	0	0	0	0	0	0	0	0	0	0	0	0	0	0	0	0	0
	Red (63)	1	1	1	1	1	1	0	0	0	0	0	0	0	0	0	0	0	0
	Green (63)	0	0	0	0	0	0	1	1	1	1	1	1	0	0	0	0	0	0
	Blue (63)	0	0	0	0	0	0	0	0	0	0	0	0	1	1	1	1	1	1
	Cyan	0	0	0	0	0	0	1	1	1	1	1	1	1	1	1	1	1	1
	Magenta	1	1	1	1	1	1	0	0	0	0	0	0	1	1	1	1	1	1
	Yellow	1	1	1	1	1	1	1	1	1	1	1	1	0	0	0	0	0	0
	White	1	1	1	1	1	1	1	1	1	1	1	1	1	1	1	1	1	1
Red	Black	0	0	0	0	0	0	0	0	0	0	0	0	0	0	0	0	0	0
	Red (1)	0	0	0	0	0	1	0	0	0	0	0	0	0	0	0	0	0	0
	Red (2)	0	0	0	0	1	0	0	0	0	0	0	0	0	0	0	0	0	0
	:	:	:	:	:	:	:	:	:	:	:	:	:	:	:	:	:	:	:
	:	:	:	:	:	:	:	:	:	:	:	:	:	:	:	:	:	:	:
	Red (61)	1	1	1	1	0	1	0	0	0	0	0	0	0	0	0	0	0	0
	Red (62)	1	1	1	1	1	0	0	0	0	0	0	0	0	0	0	0	0	0
	Red (63)	1	1	1	1	1	1	0	0	0	0	0	0	0	0	0	0	0	0
Green	Black	0	0	0	0	0	0	0	0	0	0	0	0	0	0	0	0	0	0
	Green (1)	0	0	0	0	0	0	0	0	0	0	1	0	0	0	0	0	0	0
	Green (2)	0	0	0	0	0	0	0	0	0	1	0	0	0	0	0	0	0	0
	:	:	:	:	:	:	:	:	:	:	:	:	:	:	:	:	:	:	:
	:	:	:	:	:	:	:	:	:	:	:	:	:	:	:	:	:	:	:
	Green (61)	0	0	0	0	0	0	1	1	1	1	0	1	0	0	0	0	0	0
	Green (62)	0	0	0	0	0	0	1	1	1	1	1	0	0	0	0	0	0	0
	Green (63)	0	0	0	0	0	0	1	1	1	1	1	1	0	0	0	0	0	0
Blue	Black	0	0	0	0	0	0	0	0	0	0	0	0	0	0	0	0	0	0
	Blue (1)	0	0	0	0	0	0	0	0	0	0	0	0	0	0	0	0	0	1
	Blue (2)	0	0	0	0	0	0	0	0	0	0	0	0	0	0	0	0	1	0
	:	:	:	:	:	:	:	:	:	:	:	:	:	:	:	:	:	:	:
	:	:	:	:	:	:	:	:	:	:	:	:	:	:	:	:	:	:	:
	Blue (61)	0	0	0	0	0	0	0	0	0	0	0	0	1	1	1	1	0	1
	Blue (62)	0	0	0	0	0	0	0	0	0	0	0	0	1	1	1	1	1	0
	Blue (63)	0	0	0	0	0	0	0	0	0	0	0	0	1	1	1	1	1	1

Note 1: Definition of gray scale :

Color(n)···Number in parenthesis indicates gray scale level.

Higher n corresponds to darker level.

Note 2: Data : 1 : High, 0 : Low

# 10 OUTLINE DIMENSIONS

## 10.1 FRONT VIEW

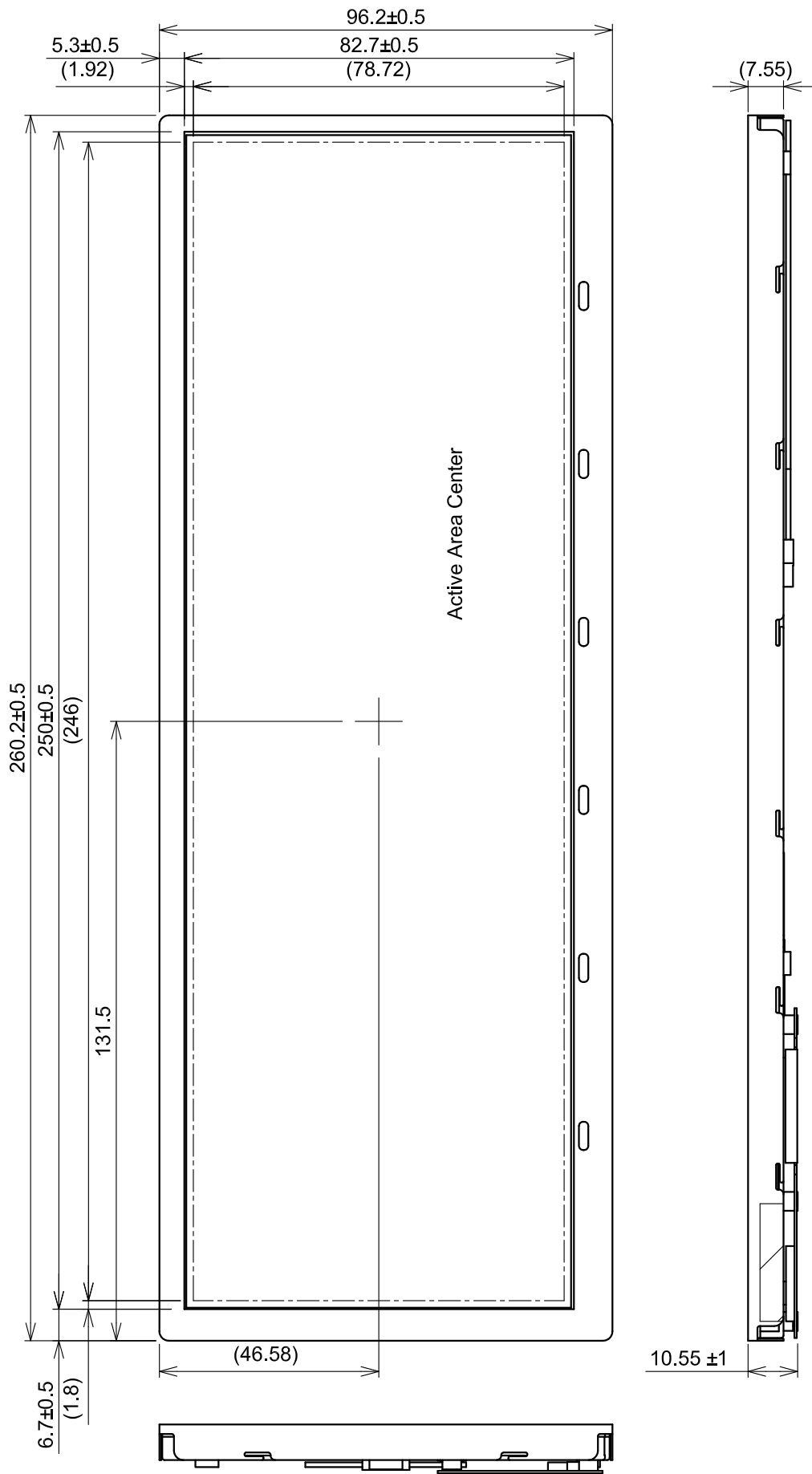

Scale : NTS  
Unit : mm



10.2 REAR VIEW

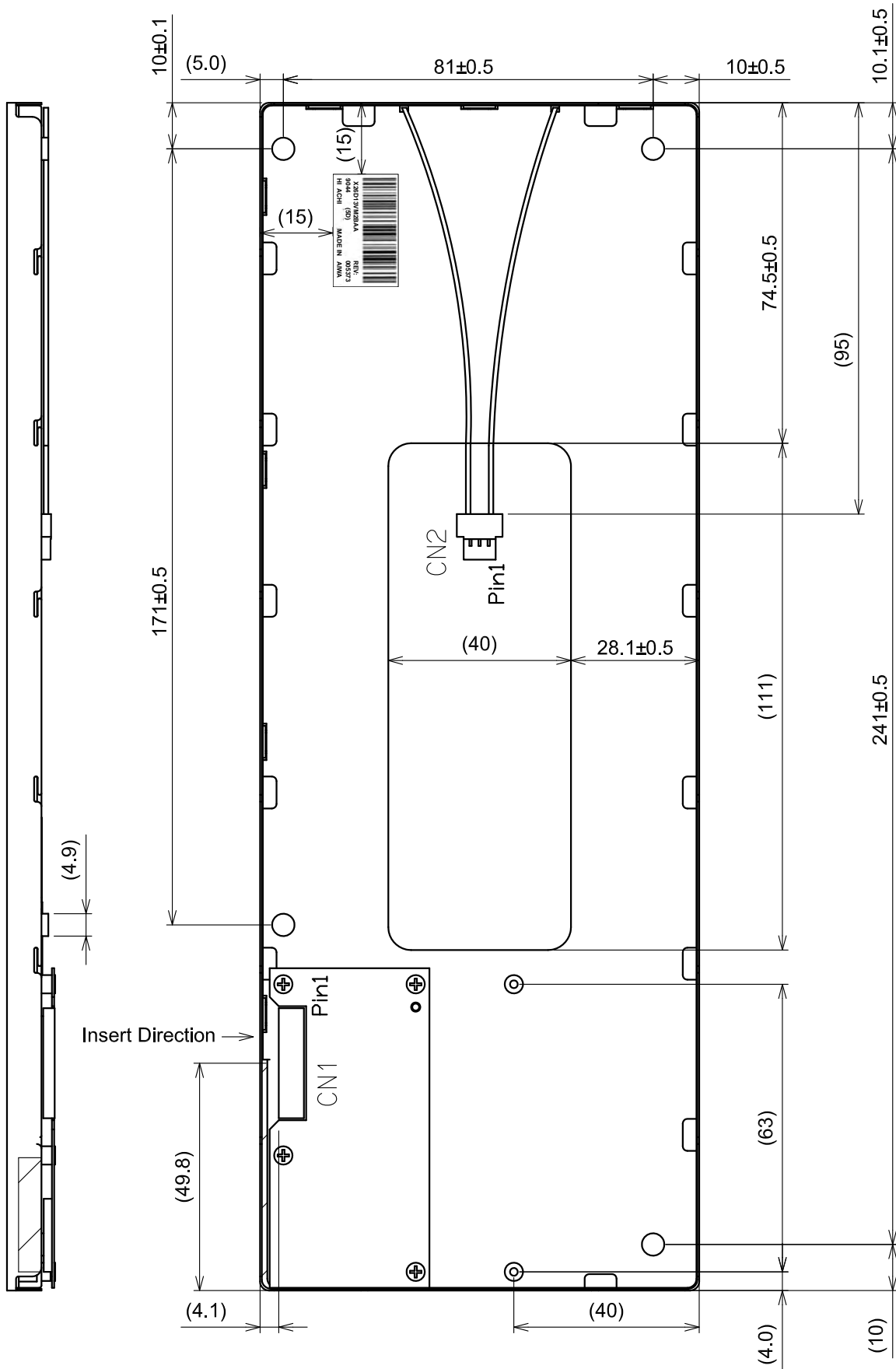

Note 1 : CN1: FA5B040HP 1R3000(JAE)

Note 2 : CN2: BHR-03VS-1(JST)

Scale : NTS  
Unit : mm

# 11. APPEARANCE STANDARD

The appearance inspection is performed in a dark room around 500~1000 lx based on the conditions as below:

- The distance between inspector's eyes and display is 30 cm.
- The viewing zone is defined with angle  $\theta$  shown in Fig. 11.1 The inspection should be performed within  $45^\circ$  when display is shutdown. The inspection should be performed within  $5^\circ$  when display is power on.

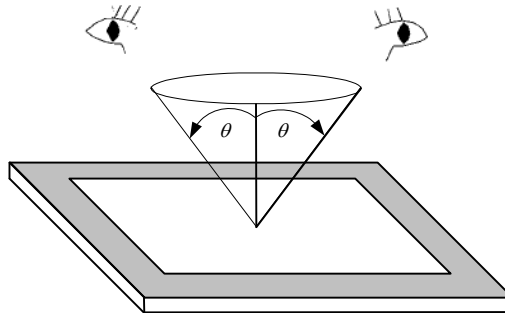

Fig. 11.1

## 11.1 THE DEFINITION OF LCD ZONE

LCD panel is divided into 3 areas as shown in Fig.11.2 for appearance specification in next section. A zone is the LCD active area (dot area); B zone is the area, which extended 1 mm out from LCD active area; C zone is the area between B zone and metal frame.

In terms of housing design, B zone is the recommended window area customers' housing should be located in.

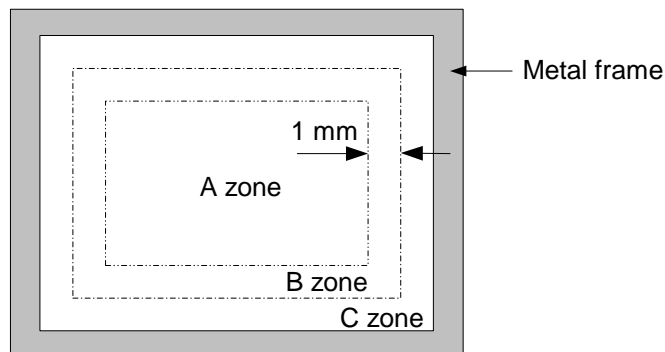

Fig. 11.2

## 11.2 LCD APPEARANCE SPECIFICATION

The specification as below is defined as the amount of unexpected phenomenon or material in different zones of LCD panel. The definitions of length, width and average diameter using in the table are shown in Fig. 11.3 and Fig. 11.4.

No	ITEM		Max. acceptable number		Unit	Remarks
			A-zone			
1	Dot defect	Sparkle mode	1-dot	5	pcs	Note 1,2,4
			2-dots	2	Units	Note 1,2,5
			3-dots	0		
			4-dots	0		
			Density	2	pcs/φ15mm	Note 1,2,6
			Total	5	pcs	Note 1,2
		Black mode	1-dot	10	pcs	Note 1,3,4
			2-dots	5	Units	Note 1,3,5
			3-dots	0		
			4-dots	0		
			Density	3	pcs/φ5mm	Note 1,3,6
			Total	10	pcs	Note 1,3
		Total		15	pcs	Note 1
		2	Line defect		Serious one is not allowed	
3	Uneven brightness				-	-
4	Stains, Foreign Materials Line shape W : width (mm) L : length (mm)	$W \leq 0.06$	L : Ignore	Ignore	pcs	Note 7
		$W \leq 0.06$	L > 0.1	See dot shape		
			L ≤ 0.1	Ignore		
5	Stains, Foreign Materials Dot shape D : ave. dia (mm)	$D \leq 0.45$		Ignore	pcs	Note 7
		$D \leq 0.7$		5		
		$D > 0.7$		0		
6	Scratch on polarizer Line shape W : width (mm) L : length (mm)	$W \leq 0.01$	L : Ignore	Ignore	pcs	Note 8
		$W \leq 0.02$	L ≤ 40	10		
			L > 40	0		
		$W \leq 0.04$	L ≤ 20	10		
			L > 20	0		
7	Scratch on polarizer Dot shape D : ave. dia (mm)	$D \leq 0.45$		Ignore	pcs	Note 8
		$D \leq 0.7$		10		
		$D > 0.7$		0		

No	ITEM	Max. acceptable number		Unit	Remarks
		A-zone			
8	Bubbles, peeling In polarizer [ D:ave.dia(mm) ]	$D \leq 0.3$	Ignore	pcs	Note 8
		$D \leq 0.5$	10		
		$D \leq 1.0$	5		
		$D > 1.0$	0		
9	Wrinkles on polarizer	Serious one is not allowed		-	-

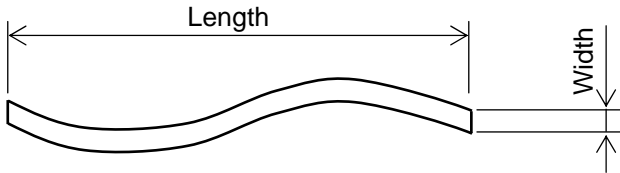

Fig 11.3

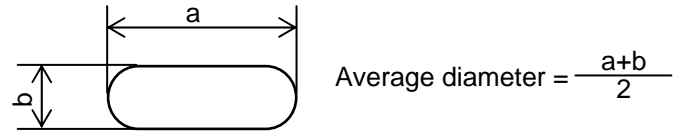

Fig 11.4

Note 1: Dot defect : defect area > 1/2 dot

Note 2: Sparkle mode : brightness of dot is more than 30% at black raster. (visible to eye)

Note 3: Black mode : brightness of dot is less than 70% at white raster. (visible to eye)

Note 4: 1 dot : defect dot is isolated, not attached to other defect dot.

Note 5: N dots : N defect dots are consecutive. (N means the number of defects dots)

Note 6: Density : number of defect dots inside 20mm  $\phi$ .

Note 7: Those stains which can be wiped out easily are not defects.

Note 8: Polarizer area inside of B-zone is not applied.

## 12. PRECAUTIONS

### 12.1 PRECAUTIONS of ESD

- 1) Before handling the display, please ensure your body has been connected to ground to avoid any damages by ESD. Also, do not touch display's interface directly when assembling.
- 1) Please remove the protection film very slowly before turning on the display to avoid generating ESD.

### 12.2 PRECAUTIONS of HANDLING

- 1) In order to keep the appearance of display in good condition, please do not rub any surfaces of the displays by using sharp tools harder than 3H, especially touch panel, metal frame and polarizer.
- 2) Please do not stack the displays as this may damage the surface. In order to avoid any injuries, please avoid touching the edge of the glass or metal frame and wore gloves during handling.
- 2) Touching the polarizer or terminal pins with bare hand should be avoided to prevent staining and poor electrical contact.
- 3) Do not use any harmful chemicals such as acetone, toluene, and isopropyl alcohol to clean display's surfaces.
- 4) Please use soft cloth or absorbent cotton with ethanol to clean the display by gently wiping. Moreover, when wiping the display, please wipe it by horizontal or vertical direction instead of circling to prevent leaving scars on the display's surface, especially polarizer.
- 5) Please wipe any unknown liquids immediately such as saliva, water or dew on the display to avoid color fading or any permanent damages.
- 6) Maximum pressure to the surface of the display must be less than  $1,96 \times 10^4$  Pa. If the area of applied pressure is less than  $1 \text{ cm}^2$ , the maximum pressure must be less than 1.96N.

### 12.3 PRECAUTIONS OF OPERATING

- 1) Please input signals and voltages to the displays according to the values defined in the section of electrical characteristics to obtain the best performance. Any voltages over than absolute maximum rating will cause permanent damages to this display. Also, any timing of the signals out of this specification would cause unexpected performance.
- 2) When the display is operating at significant low temperature, the response time will be slower than it at  $25 \text{ C}^\circ$ . In high temperature, the color will be slightly dark and blue compared to original pattern. However, these are temperature-related phenomenon of LCD and it will not cause permanent damages to the display when used within the operating temperature.
- 3) The use of screen saver or sleep mode is recommended when static images are likely for long periods of time. This is to avoid the possibility of image sticking.
- 4) Spike noise can cause malfunction of the circuit. The recommended limitation of spike noise is no bigger than  $\pm 100 \text{ mV}$ .

## 12.4 PRECAUTIONS of STORAGE

If the displays are going to be stored for years, please be aware the following notices.

- 1) Please store the displays in a dark room to avoid any damages from sunlight and other sources of UV light.
- 2) The recommended long term storage temperature is between 10C° ~35C° and 55%~75% humidity to avoid causing bubbles between polarizer and LCD glasses, and polarizer peeling from LCD glasses.
- 3) It would be better to keep the displays in the container, which is shipped from Hitachi, and do not unpack it.
- 4) Please do not stick any labels on the display surface for a long time, especially on the polarizer.

# 13 DESIGNATION of LOT MARK

1) The lot mark is showing in Fig.13.1. First 4 digits are used to represent production lot, T represented made in Taiwan, and the last 6 digits are the serial number.

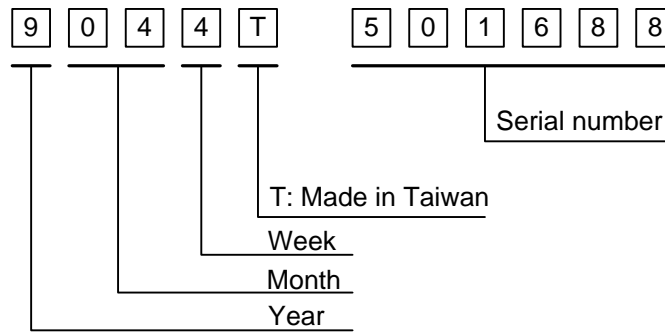

Fig. 13.1

2) The tables as below are showing what the first 4 digits of lot mark are shorted for.

Year	Lot Mark
2010	0
2011	1
2012	2
2013	3
2014	4

Month	Lot Mark	Month	Lot Mark
Jan.	01	Jul.	07
Feb.	02	Aug.	08
Mar.	03	Sep.	09
Apr.	04	Oct.	10
May	05	Nov.	11
Jun.	06	Dec.	12

Week	Lot Mark
1~7 days	1
8~14 days	2
15~21 days	3
22~28 days	4
29~31 days	5

3) Except letters I and O, revision number will be shown on lot mark and following letters A to Z.

4) The location of the lot mark is on the back of the display shown in Fig. 13.2.



Fig. 13.2