



DATE : 26. Mar. 2012

SAMSUNG TFT-LCD

MODEL : LTA460HN08-W(FHD,60HZ)

The Information Described in this Specification is Preliminary and can be changed without prior notice

LCD Business

Samsung Electronics Co . , LTD.

Revision History ----- (3)

General Description ----- (4)

General Information ----- (4)

1. Absolute Maximum Ratings ----- (5)

2. Optical Characteristics ----- (6)

3. Electrical Characteristics ----- (9)

 3.1 TFT LCD Module

 3.2 Back Light Unit

4. Input Terminal Pin Assignment ----- (11)

 4.1 Input Signal & Power

 4.2 . LS Bar Input Pin Configuration

 4.3 LVDS Interface

 4.4 Input Signals, Basic Display Colors and Gray Scale of Each Color

5. Interface Timing ----- (16)

 5.1 Timing Parameters (Stand Alone Mode)

 5.2 Timing Diagrams of interface Signal (D mode)

 5.3 Power ON/OFF Sequence

6. Outline Dimension ----- (19)

7. Packing ----- (21)

8. Marking & Others ----- (22)

9. General Precaution ----- (23)

 9.1 Handling

 9.2 Storage

 9.3 Operation

 9.4 Operation Condition Guide

 9.5 Others

*** Revision History**

Date	Rev. No	Page	Summary
26. Mar, 2012	000	-	First Issued

Description

LTY[Z]460HN05 is a color active matrix liquid crystal display (LCD) that uses amorphous silicon TFT (Thin Film Transistor) as switching components. This model is composed of a TFT LCD panel, a driver circuit and a back light unit. The resolution of a 46.0" is 1920 x 1080 and this model can display up to 1.07G colors with wide viewing angle of 89° or higher in all directions. This panel is intended to support applications to provide an excellent performance for Flat Panel Display such as Home-alone Multimedia TFT-LCD TV, Display terminals for AV application products, and High Definition TV (HDTV).

Features

- RoHS compliance (Pb-free)
- High contrast ratio, high aperture ratio, fast response time
- SPVA (Super Patterned Vertical Align) mode
- Wide viewing angle ($\pm 89^\circ$)
- Full HD (1920 x 1080 pixels) resolution (16:9)
- Low Power consumption
- WLED (White Light Emitting Diode) Backlight
- LVDS (Low Voltage Differential Signaling) interface

General Information

Items	Specification	Unit	Note
Module Size	1048.9(H _{TYP}) x 603.3(V _{TYP})	mm	±1.0mm
	26.2(D _{MAX})		
Weight	10800(Max)	g	
Pixel Pitch	0.53025(H) × 0.17675(V) * 3	mm	
Active Display Area	1018.08(H) x 572.67(V)	mm	
Surface Treatment	Haze 0.8%, Hard-coating (2H)		
Display Colors	8+2bit – 1.07G	colors	
Number of Pixels	1920 x 1080	pixel	
Pixel Arrangement	RGB Vertical stripe		
Display Mode	Normally Black		
Luminance of White	430	cd/m ²	Typ.

1. Absolute Maximum Ratings

1-1 Operating Condition

If the condition exceeds maximum ratings, it can cause malfunction or unrecoverable damage to the device.

Item	Symbol	Min.	Max.	Unit	Note
Power Supply Voltage	V_{DD}	GND-0.5	13	V	(1)
Module Storage Temperature	T_{STG}	-20	60	°C	(2)
Operating Temperature	T_{OPR}	0	50	°C	(2)
Shock (non – operating)	S_{NOP}	-	30	G	(4)
Vibration (non – operating)	V_{NOP}	-	1.5	G	(5)

Note (1) $T_a = 25 \pm 2 \text{ }^\circ\text{C}$

(2) Temperature and relative humidity range are shown in the figure below.

a. 93.8 % RH Max. ($T_a \leq 40 \text{ }^\circ\text{C}$)

b. Maximum wet-bulb temperature at $40 \text{ }^\circ\text{C}$ or less. ($T_a \leq 40 \text{ }^\circ\text{C}$)

c. No condensation

(3) Polarizer will not be damaged in this range, even though abnormal visual problems occur in T_{SUR} range.

(4) 11ms, sine wave, one time for $\pm X, \pm Y, \pm Z$ axis

(5) 10-300 Hz, Sweep rate 10min, 30min for X, Y, Z axis

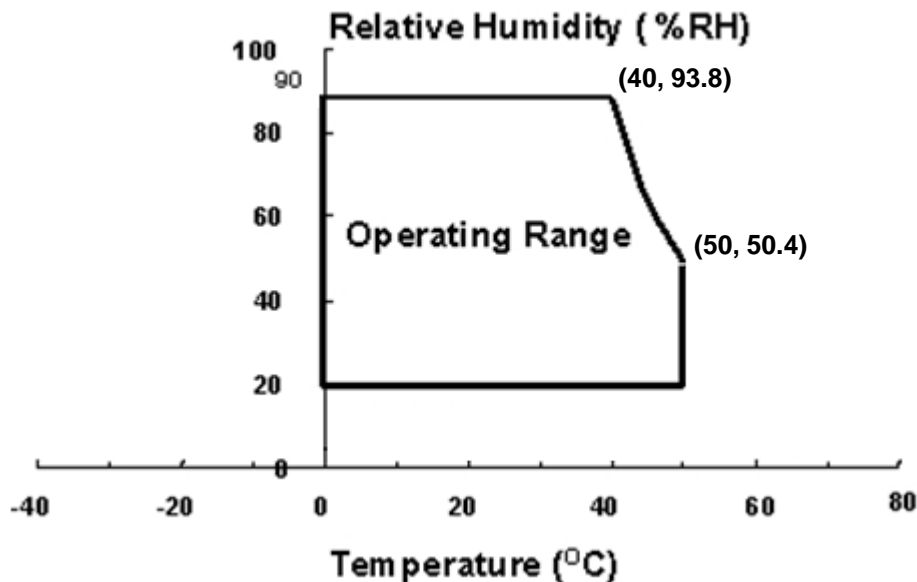

Fig. Temperature and Relative humidity range

2. Optical Characteristics

Samsung Secret

The optical characteristics should be measured in a dark room or equivalent.

Measuring equipment : TOPCON BM-7, SPECTRORADIOMETER SR-3

(LED Input Current = 130mA, Ta = 25 ± 2°C, VDD=12V, fv= 60Hz, f_{DCLK}=148.5MHz, Dim = 100%)

Item	Symbol	Condition	Min.	Typ.	Max.	Unit	Note	
Contrast Ratio (Center of screen)	C/R	Normal $\theta_{L,R}=0$ $\theta_{U,D}=0$ Viewing Angle	*3000	4000	-		(3) SR-3A	
Response Time	G-to-G [AVE]		Tg	-	8	16	msec	(5) RD-80S
Luminance of White (Center of screen)	Y _L			360	430	-	cd/m ²	(6) SR-3A
Color Chromaticity (CIE 1931)	Red		Rx	TYP. -0.03	0.641	TYP. +0.03		(7),(8) SR-3A
			Ry		0.331			
	Green		Gx		0.313			
			Gy		0.613			
	Blue		Bx		0.155			
			By		0.056			
	White		Wx		0.280			
		Wy	0.285					
Color Gamut	-		-	70	-	%	(7) SR-3A	
Color Temperature	-		-	10000	-	K	(9)	
Viewing Angle	Hor.	θ_L	C/R≥10	79	89	-	Degree	(8) EZ-Contrast
		θ_R		79	89	-		
	Ver.	θ_U		79	89	-		
		θ_D		79	89	-		
Brightness Uniformity (9 Points)	B _{uni}		-	-	30	%	(4) SR-3	

* CR = (White at point ⑤ of Note 2) / (Most Dark Point of Black Pattern at area ① of Note 2)

Note (1) Test Equipment Setup

The measurement should be executed in a stable, windless and dark room between 40min and 60min after lighting the back light at the given temperature for stabilization of the back light. This should be measured in the center of screen.

Single lamp current @ Vdim = 100%
Environment condition : Ta = 25 ± 2 °C

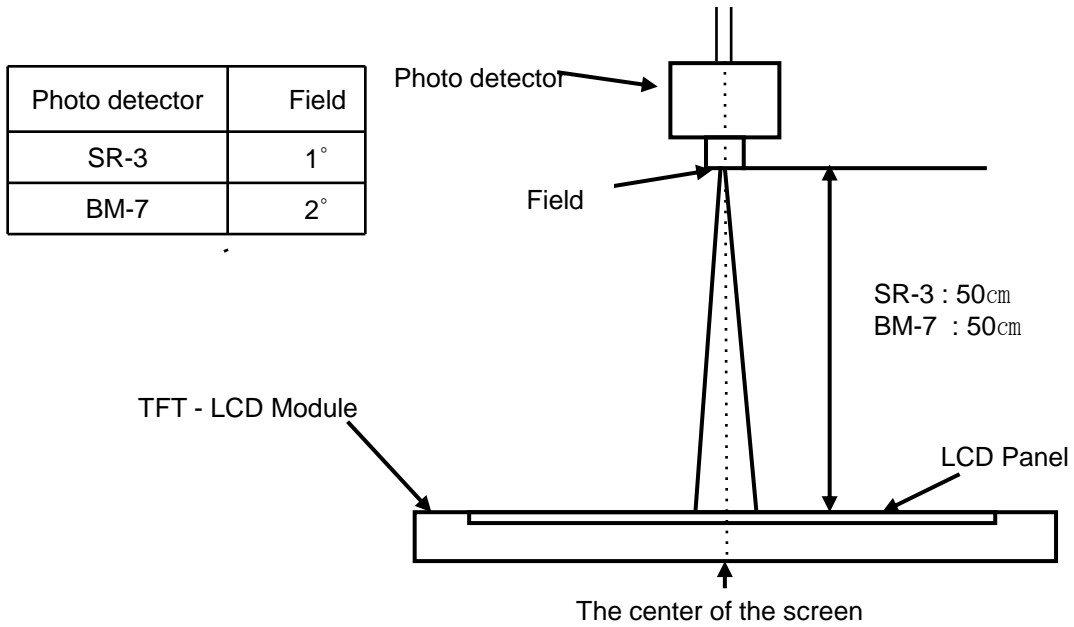

Note (2) Definition of test point

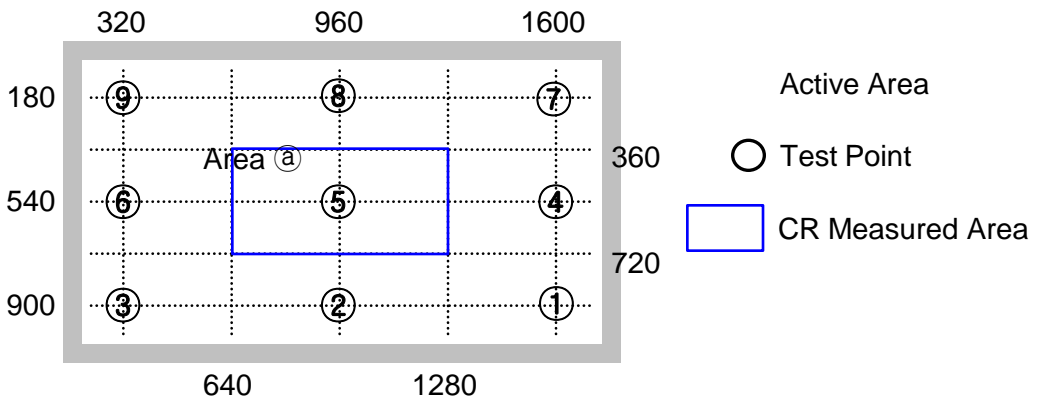

Note (3) Definition of Contrast Ratio (C/R)

: Ratio of gray max (Gmax) & gray min (Gmin) at the center point ⑤ of the panel

$$C/R = \frac{G_{\max}}{G_{\min}}$$

Gmax : Luminance with all pixels white

Gmin : Luminance with all pixels black

Note (4) Definition of 9 points brightness uniformity

$$B_{uni} = 100 * \frac{(B_{max} - B_{min})}{B_{max}}$$

B_{max} : Maximum brightness

B_{min} : Minimum brightness

Note (5) Definition of Response time : Sum of Tr, Tf

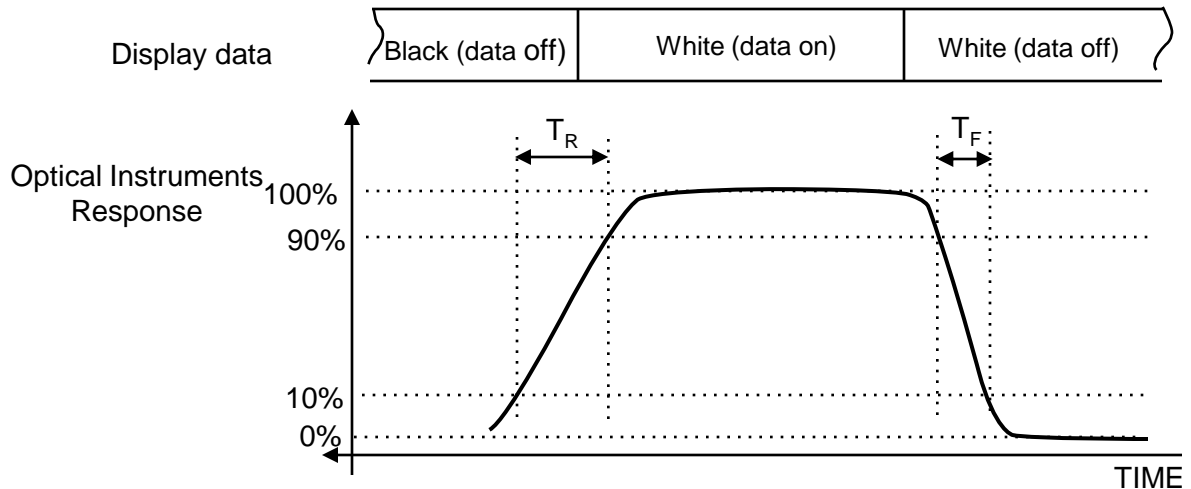

Note (6) Definition of Luminance of White : Luminance of white at center point ⑤

Note (7) Definition of Color Chromaticity (CIE 1931)

Color coordinate of Red, Green, Blue & White at center point ⑤

Note (8) Definition of Viewing Angle

: Viewing angle range (C/R ≥ 10)

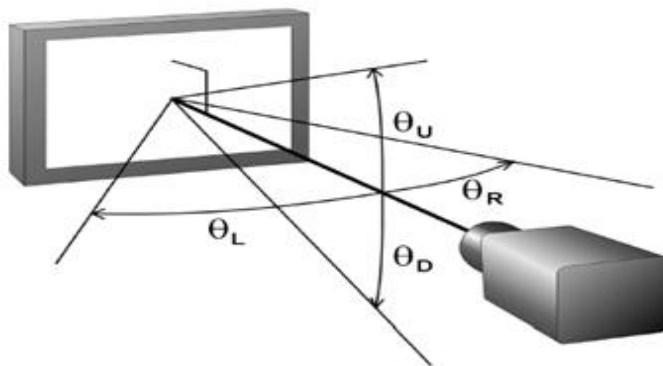

Note (9) Definition of 2 point Gamma

$$Gamma = \log(X_{lum}/100)/\log(Y/100)$$

$$X_{lum} = (Z - B_{min}) / (B_{max} - B_{min}) \times 100$$

Y: Measurement Level / Z: Measurement Brightness

B_{max}: Maximum Brightness / B_{min}: Minimum Brightness

3. Electrical Characteristics

3.1 TFT LCD Module

The connector for display data & timing signal should be connected.

$T_a = 25^\circ\text{C} \pm 2^\circ\text{C}$

Item	Symbol	Min.	Typ.	Max.	Unit	Note
Voltage of Power Supply	V_{DD}	11	12	13	V	(1)
Current of Power Supply	(a) Black	-	450	900	mA	(2),(3)
	(b) White	-	470	920		
	(c) Mosaic	-	470	920		
	(4) Max Pattern	-	830	1590		
Vsync Frequency	f_V	47	60	62	Hz	
Hsync Frequency	f_H	50	67.5	73	kHz	
Main Frequency	f_{DCLK}	130	148.5	155	MHz	
Rush Current	I_{RUSH}	-	-	3	A	(4)

Note (1) The ripple voltage should be controlled under 10% of V_{DD} .

(2) $f_V=60\text{Hz}$, $f_{DCLK} = 148.5\text{MHz}$, $V_{DD} = 12.0\text{V}$, DC Current.

(3) Power dissipation check pattern (LCD Module only)

a) Black Pattern

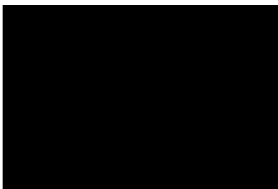

b) White Pattern



c) Mosaic

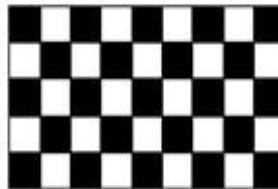

d) Max. Pattern



(4) Measurement Conditions

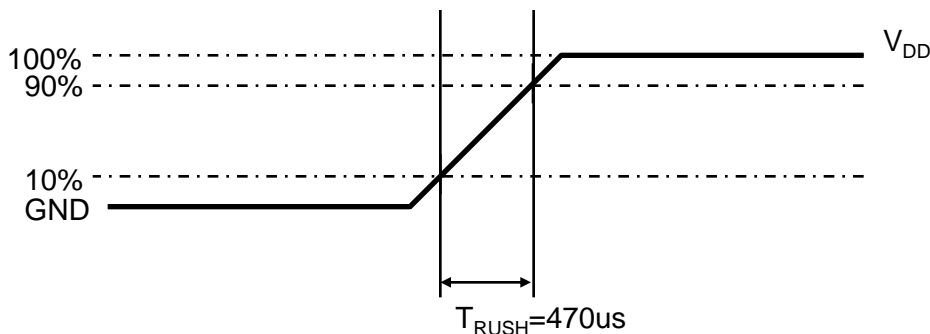

Rush Current I_{RUSH} can be measured when T_{RUSH} is 1ms

3.2 Back Light Unit

The back light contains 88 LEDs.

The characteristics of lamps are shown in the following tables.

Ta=25 ± 2°C

Item		Symbol	Min.	Typ.	Max.	Unit	Note
Operating Life Time		Hr	30,000	-	-	Hour	(1)
Operating Current	Continuous	I _{op}	-	130	260	mA	
Operating Voltage	Continuous	V _{op}	257	-	293	V	@140mA / 44LEDs @Ta 25°C
Range of Voltage		ΔVf	-	-	11.5	V	@140mA / String

Note (1) It is defined as the time to take until the brightness reduces to 50% of its original value at each String, I_{op}=110.0mA

[Definition of Operating Voltage : At each Strings, I_{op} = 140.0 mA (typ.)]

3.2.1 Review and Update for Electrical Specification

According to the improvement of efficiency for devices, the electrical specification would be reviewed and revised after initial values had been established. This revision mentioned above should be discussed at appropriate time.

4. Input Terminal Pin Assignment

4.1. Input Signal & Power of Control Board

1. 51Pin Connector : FI-RNE51SZ-HF (JAE)

PIN No.	Signal	Description	PIN No.	Signal	Description
1	Vin	Power	26	RE[0]P	Even LVDS Signal +
2	Vin	Power	27	RE[1]N	Even LVDS Signal -
3	Vin	Power	28	RE[1]P	Even LVDS Signal +
4	Vin	Power	29	RE[2]N	Even LVDS Signal -
5	Vin	Power	30	RE[2]P	Even LVDS Signal +
6	N.C.	No Connection	31	GND	GND
7	GND	GND	32	RECLKN	Even LVDS CLK -
8	GND	GND	33	RECLKP	Even LVDS CLK +
9	GND	GND	34	GND	GND
10	RO[0]N	Odd LVDS Signal -	35	RE[3]N	Even LVDS Signal -
11	RO[0]P	Odd LVDS Signal +	36	RE[3]P	Even LVDS Signal +
12	RO[1]N	Odd LVDS Signal -	37	RE[4]N	Even LVDS Signal -
13	RO[1]P	Odd LVDS Signal +	38	RE[4]P	Even LVDS Signal +
14	RO[2]N	Odd LVDS Signal -	39	GND	GND
15	RO[2]P	Odd LVDS Signal +	40	N.C.	No Connection
16	GND	GND	41	N.C.	No Connection
17	ROCLKN	Odd LVDS CLK -	42	N.C.	No Connection
18	ROCLKP	Odd LVDS CLK +	43	N.C.	No Connection
19	GND	GND	44	N.C.	No Connection
20	RO[3]N	Odd LVDS Signal -	45	N.C.	No Connection
21	RO[3]P	Odd LVDS Signal +	46	N.C.	No Connection
22	RO[4]N	Odd LVDS Signal -	47	N.C.	No Connection
23	RO[4]P	Odd LVDS Signal +	48	N.C.	No Connection
24	GND	GND	49	N.C.	No Connection
25	RE[0]N	Even LVDS Signal -	50	N.C.	No Connection
			51	SEL1	LVDS Option

■ Option Pin Description

These pins are CMOS interface.

Please use within the range of the following restriction.

VIH : 2.4V(min) / 3.5V(max)

VIL : 0.0V(min) / 0.4V(max)

Note(1) Pin number starts from Right side

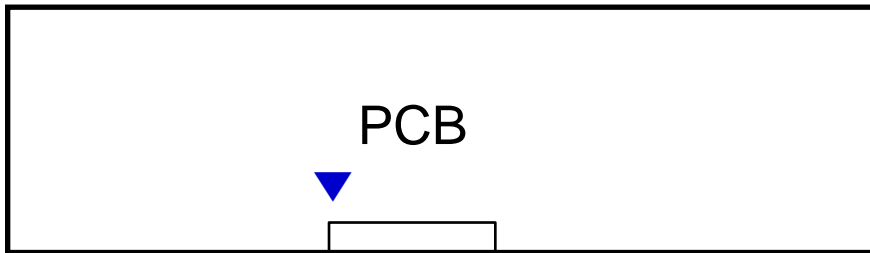

A. 51 Pin

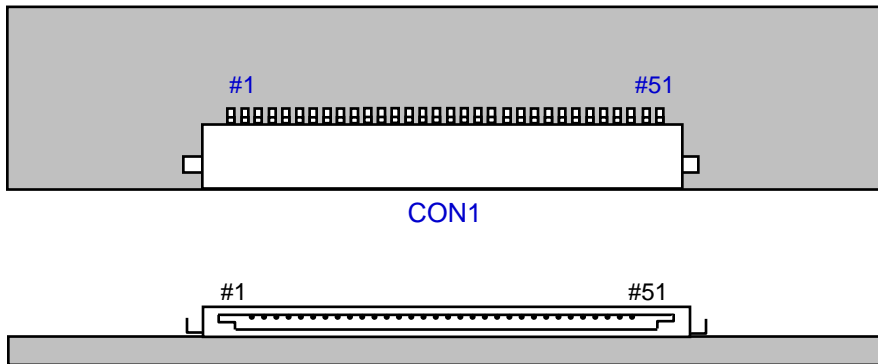

Fig. Connector diagram

- a. All GND pins should be connected together and also be connected to the LCD's metal chassis.
- b. All power input pins should be connected together.
- c. All NC pins should be separated from other signal or power.

4.2. LS Bar Input Pin Configuration

1. CONNECTOR : Morex/51103-040

Pin	Pin Configuration (Function)
1	DC Voltage (+)
2	N.C.
3	N.C.
4	DC Voltage (+)

2. CONNECTOR : Morex/51103-0500

Pin	Pin Configuration (Function)
1	Feedback
2	N.C.
3	N.C.
4	Feedback
5	N.C.

4.3 LVDS Interface

	LVDS pin	Odd Data	Even Data
TxOUT/RxIN0	TxIN/RxOUT0	R0	R0
	TxIN/RxOUT1	R1	R1
	TxIN/RxOUT2	R2	R2
	TxIN/RxOUT3	R3	R3
	TxIN/RxOUT4	R4	R4
	TxIN/RxOUT6	R5	R5
	TxIN/RxOUT7	G0	G0
TxOUT/RxIN1	TxIN/RxOUT8	G1	G1
	TxIN/RxOUT9	G2	G2
	TxIN/RxOUT12	G3	G3
	TxIN/RxOUT13	G4	G4
	TxIN/RxOUT14	G5	G5
	TxIN/RxOUT15	B0	B0
	TxIN/RxOUT18	B1	B1
TxOUT/RxIN2	TxIN/RxOUT19	B2	B2
	TxIN/RxOUT20	B3	B3
	TxIN/RxOUT21	B4	B4
	TxIN/RxOUT22	B5	B5
	TxIN/RxOUT24	HSYNC	HSYNC
	TxIN/RxOUT25	VSYNC	VSYNC
	TxIN/RxOUT26	DEN	DEN
TxOUT/RxIN3	TxIN/RxOUT27	R6	R6
	TxIN/RxOUT5	R7	R7
	TxIN/RxOUT10	G6	G6
	TxIN/RxOUT11	G7	G7
	TxIN/RxOUT16	B6	B6
	TxIN/RxOUT17	B7	B7
	TxIN/RxOUT23	Reserved	Reserved
TxOUT/RxIN4	TxIN/RxOUT28	R8	R8
	TxIN/RxOUT29	R9	R9
	TxIN/RxOUT30	G8	G8
	TxIN/RxOUT31	G9	G9
	TxIN/RxOUT32	B8	B8
	TxIN/RxOUT33	B9	B9
	TxIN/RxOUT34	Reserved	Reserved

5. Interface Timing

5.1 Timing Parameters

5.1.1 DE Mode

SIGNAL	ITEM	SYMBOL	MIN.	TYP.	MAX.	Unit	Note
Clock	Frequency	1/Tc	130.00	148.50	155.00	MHz	
Hsync		FH	50	67.5	73	kHz	Polarity : Negative
Vsync		FV	47	60	63	Hz	Polarity : Negative
Vertical Active	Display Period	TVD	1080	1080	1080	Lines	
	Vertical Total	TV	1100	1125	1480	Lines	
Horizontal Active	Display Period	THD	1920	1920	1920	clocks	
	Horizontal Total	TH	2145	2200	2450	clocks	

5.2 Timing diagrams of interface signal (DE only mode)

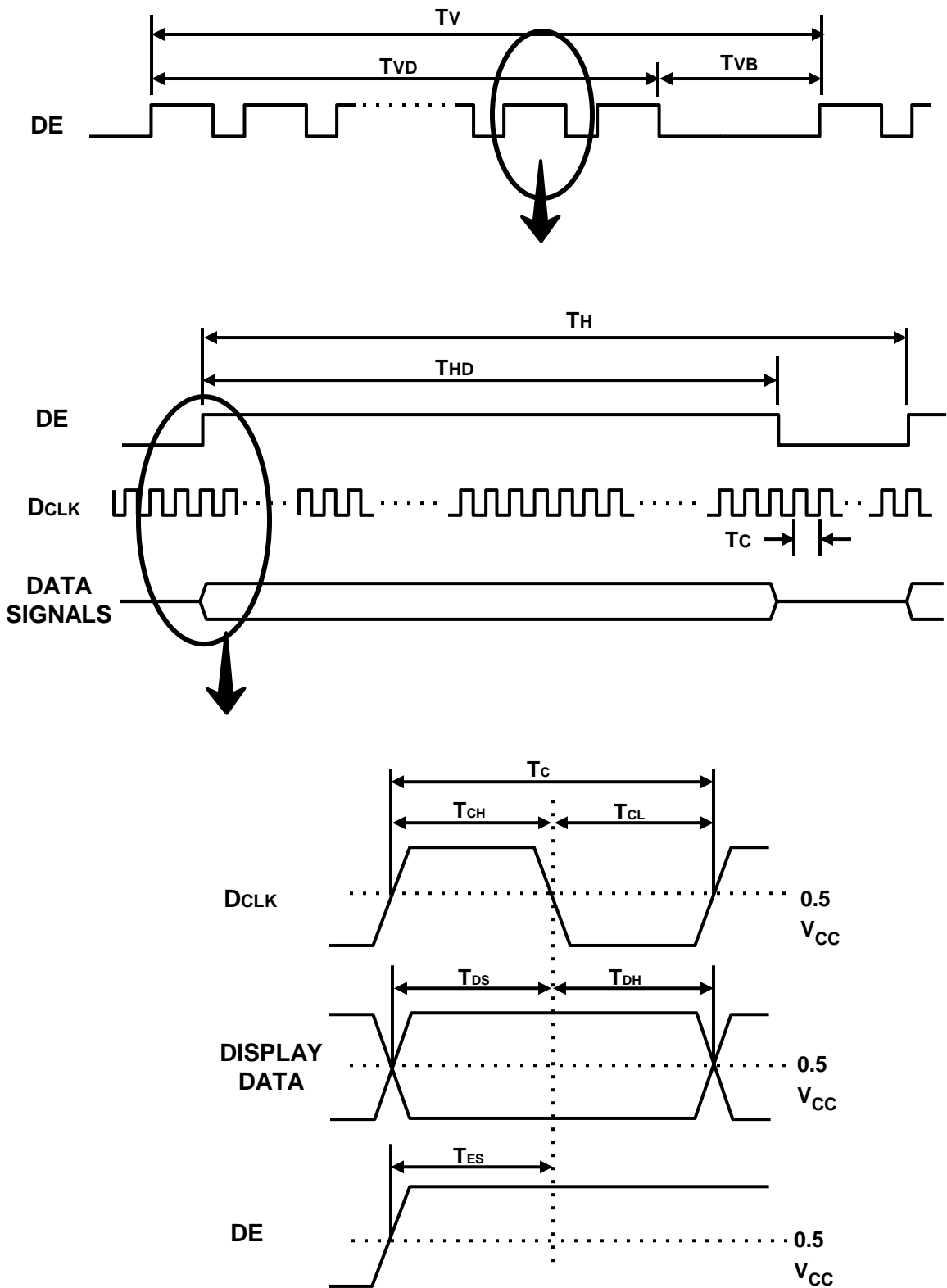

5.3 Power ON/OFF Sequence

To prevent a latch-up or DC operation of the LCD Module, the power on/off sequence should be as the diagram below.

- 0.47ms < T1 ≤ 30ms
- 10ms < T2 ≤ 50ms
- 0ms < T3 ≤ 50ms
- 1000ms < T4
- 550ms ≤ T5
- 60ms ≤ T6
- 1ms ≤ T8

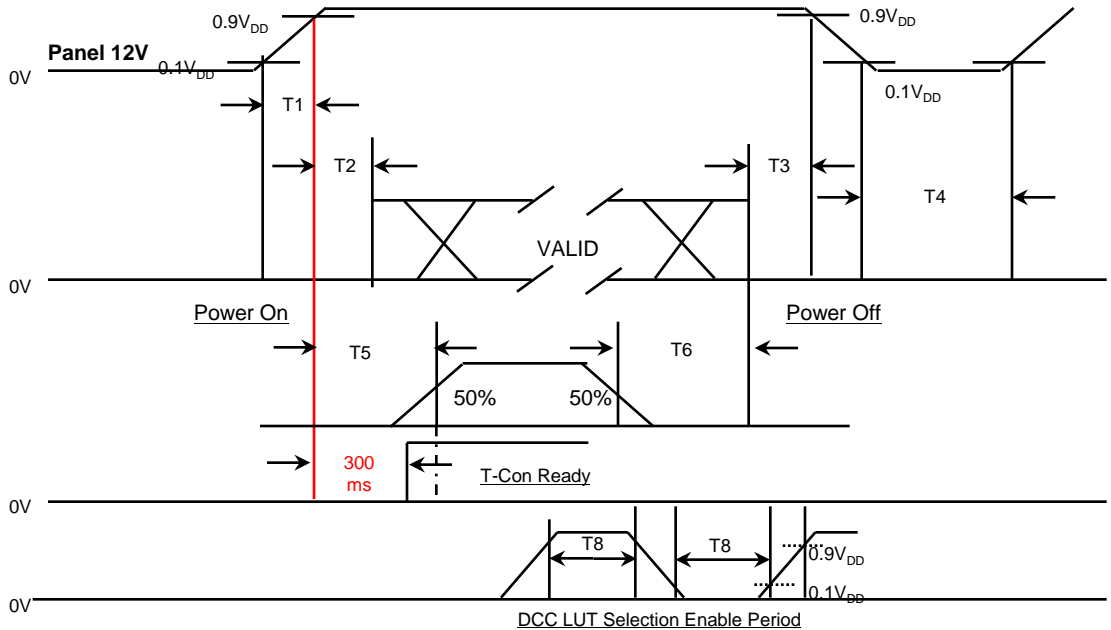

- T1 : V_{DD} rising time from 10% to 90%
- T2 : The time from V_{DD} to valid data at power ON.
- T3 : The time from valid data off to V_{DD} off at power Off.
- T4 : V_{DD} off time for Windows restart
- T5 : The time from valid data to B/L enable at power ON.
- T6 : The time from valid data off to B/L disable at power Off.
- T8 : DCC LUT Selection Enable Period.

[Valid Data Condition]

1. Input LVDS signals must satisfy "Interface Timing" Specification on p23.
2. LVDS Clock must keep the same frequency.
3. "Temp SEL" signal should be changed within Tcon Reset and Tcon Ready.
4. Data signal should not input during "Fail Safe Mode".

- The supply voltage of the external system for the Module input should be the same as the definition of V_{DD}.
- Apply the lamp voltage within the LCD operation range. When the back light turns on before the LCD operation or the LCD turns off before the back light turns off, the display may momentarily show abnormal screen.
- In case of V_{DD} = off level, please keep the level of input signals low or keep a high impedance.
- T4 should be measured after the Module has been fully discharged between power off and on period.
- Interface signal should not be kept at high impedance when the power is on.

6.1 Outline Dimension

a. Front View

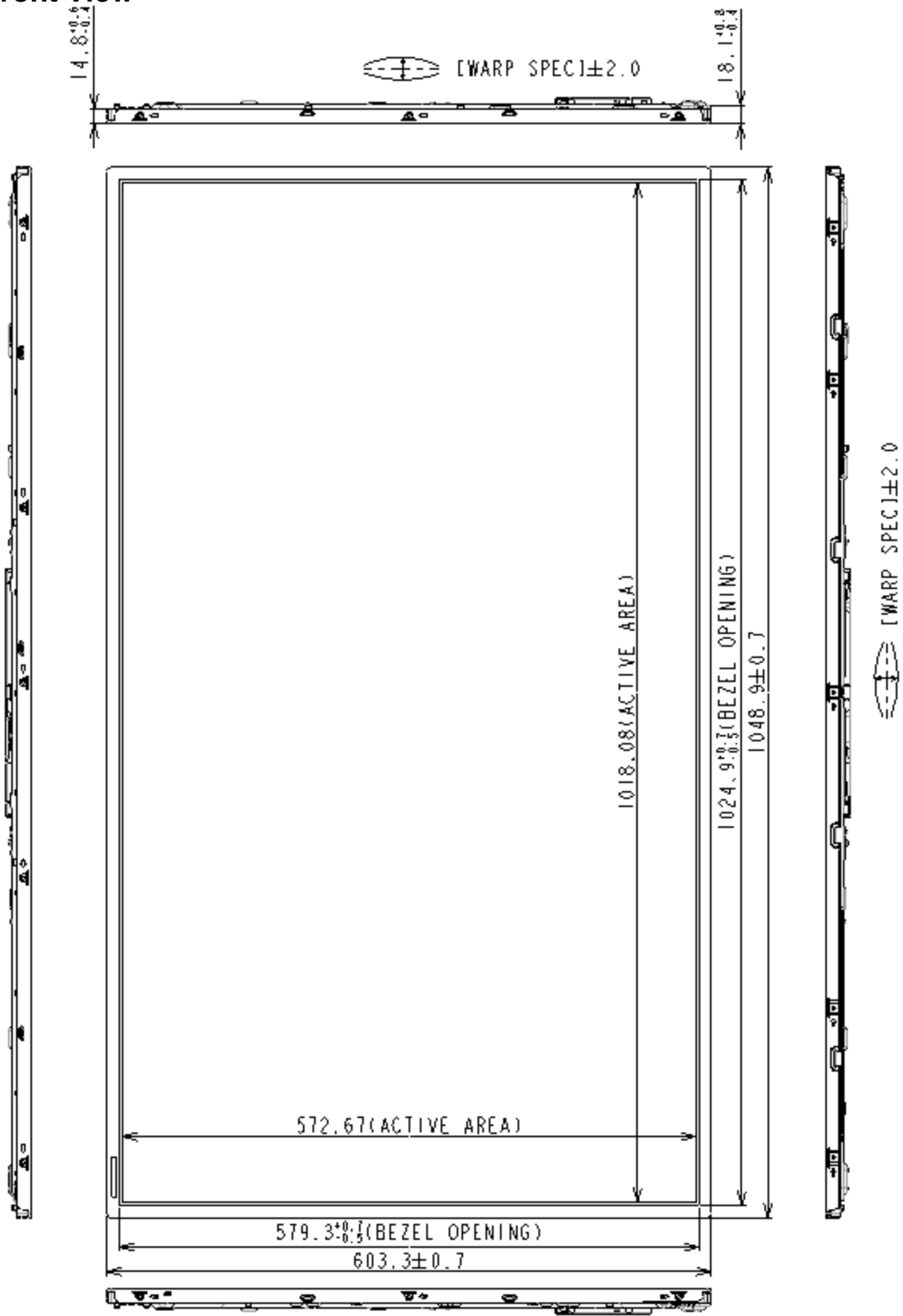

6.1 Outline Dimension

b. Rear View

EMBOSS TOP SURFACE HEIGHT DIFFERENCE IS MAX 0.7

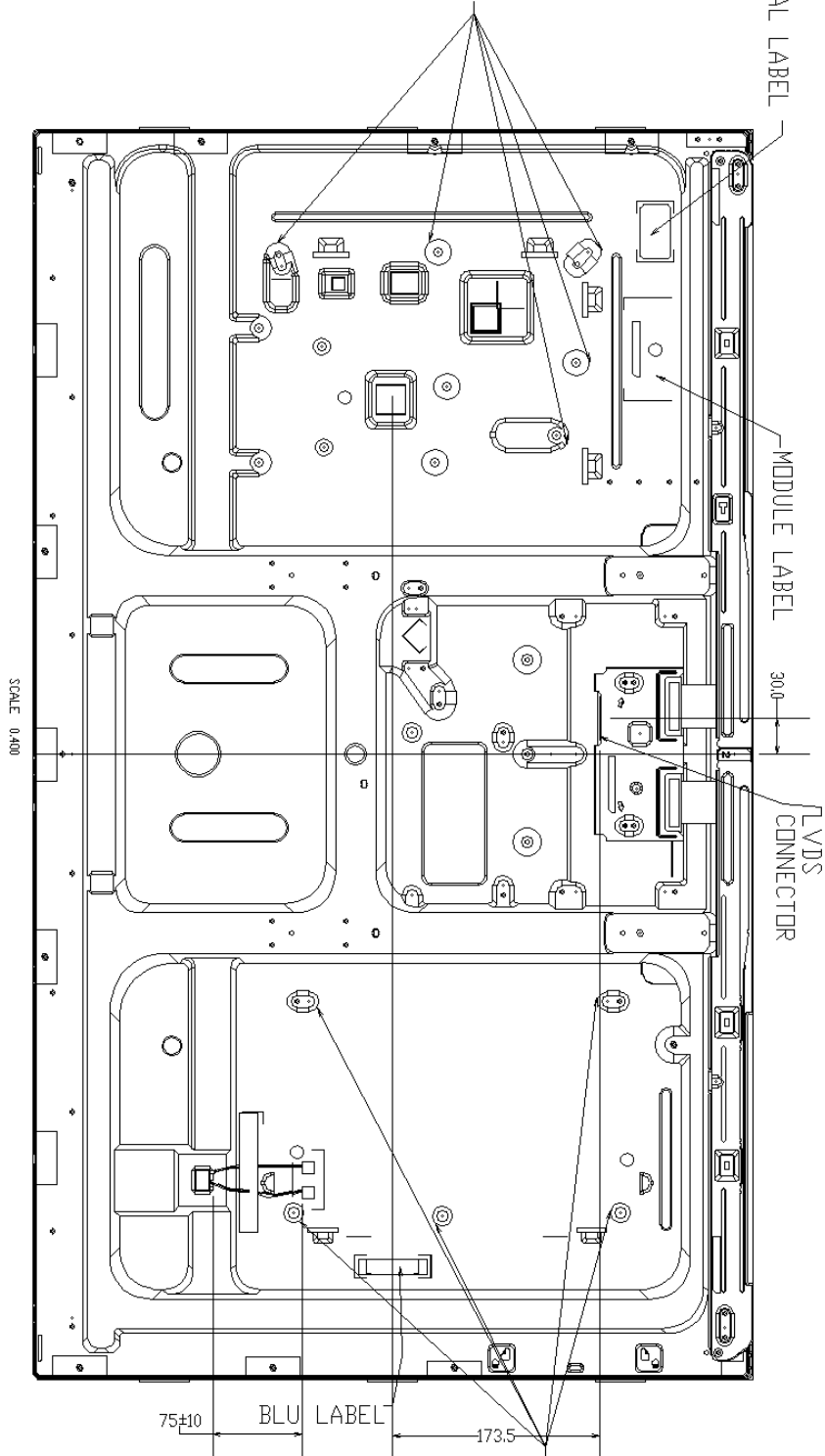

EMBOSS TOP SURFACE HEIGHT DIFFERENCE IS MAX 0.7

* TAPE TO HOLD CABLE SHALL BE FOLDED TO ENABLE TO BE REMOVED EASILY.

7. PACKING

Samsung Secret

7.1 CARTON (Internal Package)

(1) Packing Form

Corrugated fiberboard box and corrugated cardboard as shock absorber

(2) Packing Method

Packing Box

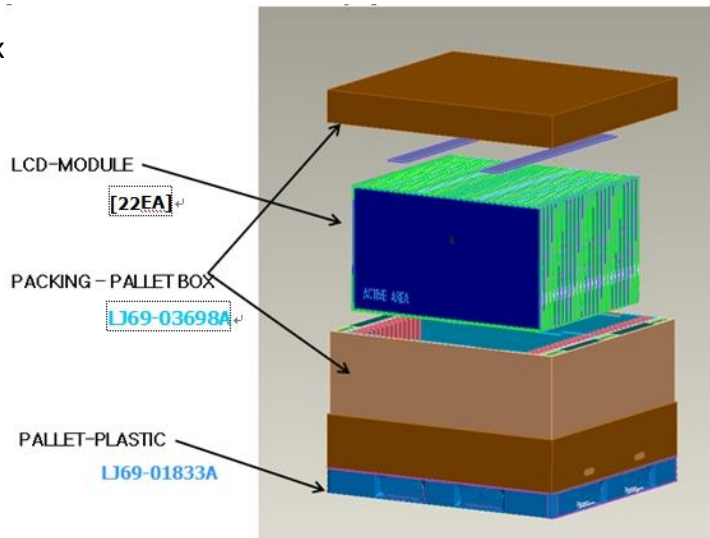

7.2 Packing Specification

Item	Specification	Remark
LCD Packing	22ea / (Packing Box)	1. 220kg/LCD(22ea) 2. 28kg/Packing Box(1ea) 3. Packing Box Material : Paper
Desiccant (Drier)	6ea / LCD	10g/ea, Cobalt-dichloride-free
Pallet	1Box / Pallet	Pallet weight : 7.8kg
Packing Direction	Vertical	-
Total Pallet Size	L x W x Height	1270mm x 1150mm x 785mm
Total Pallet Weight	257kg	Pallet(7.8kg) + Module(22 x 10kg = 220kg) + Packing BOX(28kg) + Desiccant(0.06kg x 22 = 1.32kg)
Stack Layer	-	
Shielding Bag	Compound PE / Sealing / 70 μ m	Material / Adhesive tape / Thickness
POL Protection Film	PET / 0.125mm	Material / Thickness

8. MARKING & OTHERS

A nameplate bearing followed by is affixed to a shipped product at the specified location on each product.

- (1) Parts number : LTY[Z]460HN05-XXX
- (2) Revision: One letters
- (3) Lot number : X X X X XXX XX X

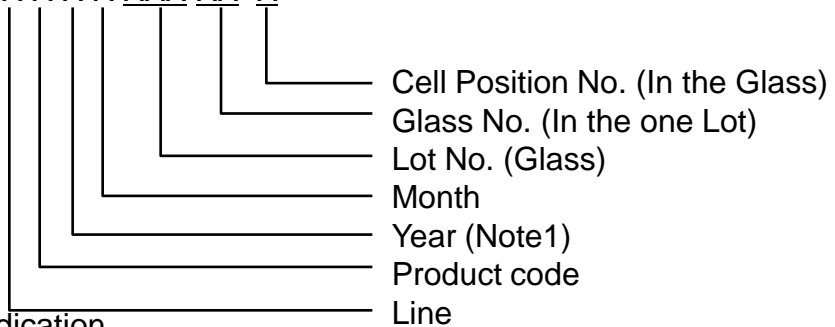

(4) Nameplate Indication

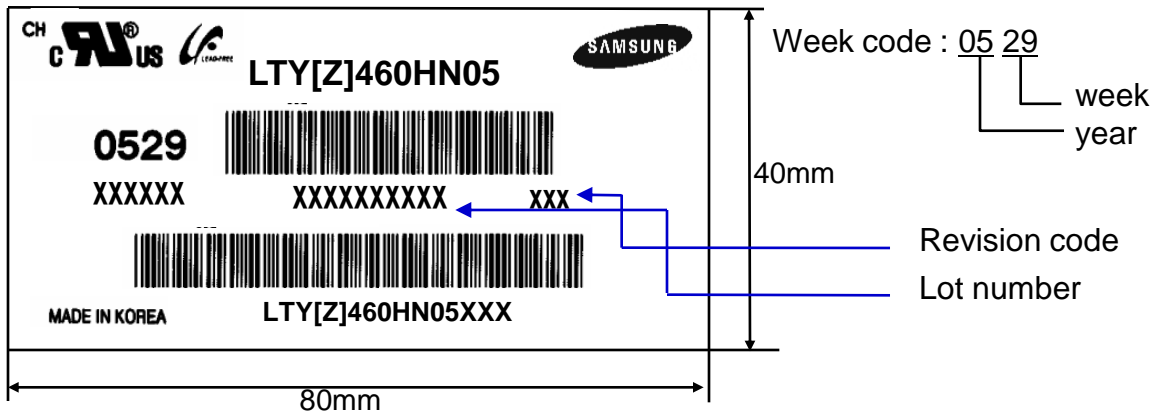

(5) Packing box attach

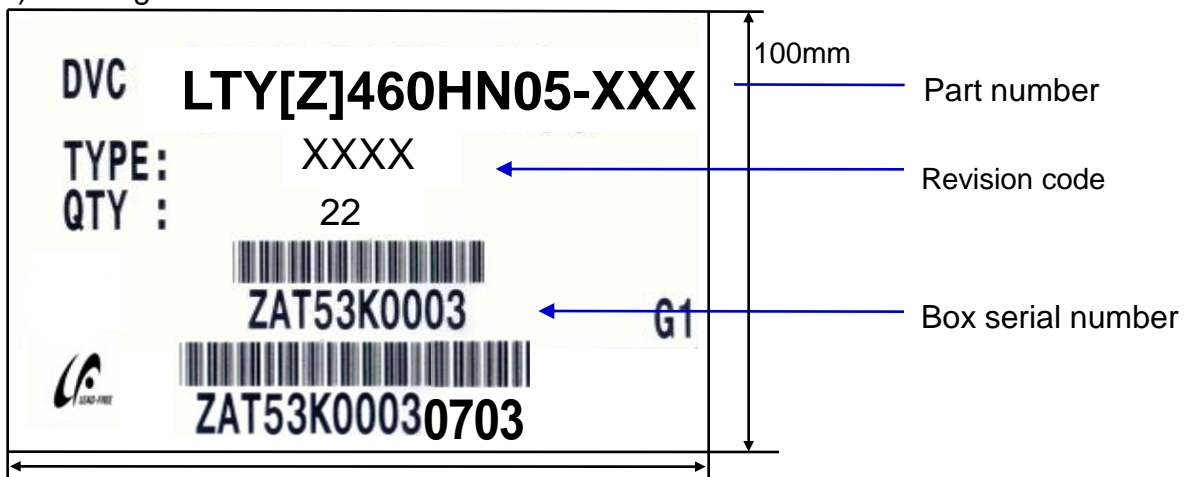

(6) Others

- 1. After service part
 Lamps cannot be replaced because of the narrow bezel structure.

9. General Precautions

9.1 Handling

- (a) When the Module is assembled, it should be attached to the system firmly using all mounting holes. Be careful not to twist and bend the Module.
- (b) Because the inverter use high voltage, it should be disconnected from power before it is assembled or disassembled.
- (c) Refrain from strong mechanical shock and / or any force to the Module. In addition to damage, this may cause improper operation or damage to the Module and back light.
- (d) Note that polarizers are very fragile and could be damage easily. Do not press or scratch the surface harder than a HB pencil lead.
- (e) Wipe off water droplets or oil immediately. If you leave the droplets for a long time, staining or discoloration may occur.
- (f) If the surface of the polarizer is dirty, clean it using absorbent cotton or soft cloth.
- (g) Desirable cleaners are water, IPA(Isopropyl Alcohol) or Hexane. Do not use Ketone type materials(ex. Acetone), Ethyl alcohol, Toluene, Ethyl acid or Methyl chloride. It might permanent damage to the polarizer due to chemical reaction.
- (h) If the liquid crystal material leaks from the panel, it should be kept away from the eyes or mouth . In case of contact with hands, legs or clothes, it must be washed away with soap thoroughly.
- (i) Protect the Module from static, or the CMOS Gate Array IC would be damaged.
- (j) Use finger-stalls with soft gloves in order to keep display clean during the incoming inspection and assembly process.
- (k) Do not disassemble the Module.
- (l) Do not pull or fold the LED FFC.
- (m) Do not adjust the variable resistor located on the Module.
- (n) Protection film for polarizer on the Module should be slowly peeled off just before use so that the electrostatic charge can be minimized.
- (o) Pins of I/F connector should not be touched directly with bare hands.

9.2 Storage

We highly recommend to comply with the criteria in the table below.

Item	Unit	Min.	Max.
Storage Temperature	(°C)	10	40
Storage Humidity	(%rH)	35	75
Storage Life	12 Months		
Storage Condition	<ul style="list-style-type: none"> - The storage room should provide good ventilation and temperature control. - Products should not be placed on the floor, but on the Pallet away from a wall. - Prevent products from direct sunlight, moisture nor water; Be cautious of a build up of condensation. - Avoid other hazardous environment while storing goods. - If products delivered or kept in conditions of over the storage period of 3 months, the recommended temperature or humidity range, we recommend you leave them at a temperature of 20 °C and a humidity of 50% for 24 hours. 		

9.3 Operation

- (a) No Connection or disconnect the Module in the "Power On" condition.
- (b) Power supply should always be turned on/off by the "Power on/off sequence"
- (c) Module has high frequency circuits. Sufficient suppression to the electromagnetic interference should be done by system manufacturers. Grounding and shielding methods may be important to minimize the interference.
- (d) The cable between the back light connector and its Converter power supply should be connected directly with a minimized length. A longer cable between the back light and the inverter may cause lower luminance of LED and may require higher startup voltage(Vs).

- (a) The LCD product should be operated under normal conditions.
Normal condition is defined as below;
- Temperature : 20 ± 15 °C
 - Humidity : 55 ± 20 %
 - Display pattern : continually changing pattern (Not stationary)
- (b) If the product will be used in extreme conditions such as high temperature, humidity, display patterns or operation time etc., It is strongly recommended to contact SEC for Application engineering advice. Otherwise, its reliability and function may not be guaranteed. Extreme conditions are commonly found at Airports, Transit Stations, Banks, Stock market, and Controlling systems.

9.5 Others

- (a) Ultra-violet ray filter is necessary for outdoor operation.
- (b) Avoid condensation of water. It may result in improper operation or disconnection of electrode.
- (c) Do not exceed the absolute maximum rating value. (supply voltage variation, input voltage variation, variation in part contents and environmental temperature, and so on)
Otherwise the Module may be damaged.
- (d) If the Module keeps displaying the same pattern for a long period of time, the image may be "sticked" to the screen.
To avoid image sticking, it is recommended to use a screen saver.
- (e) This Module has its circuitry PCB's on the rear side and should be handled carefully in order not to be stressed.
- (f) Please contact SEC in advance when you display the same pattern for a long time.