

10.2 A 715G6463 PSU
10-2-1 AC input

A01 AC INPUT

A01

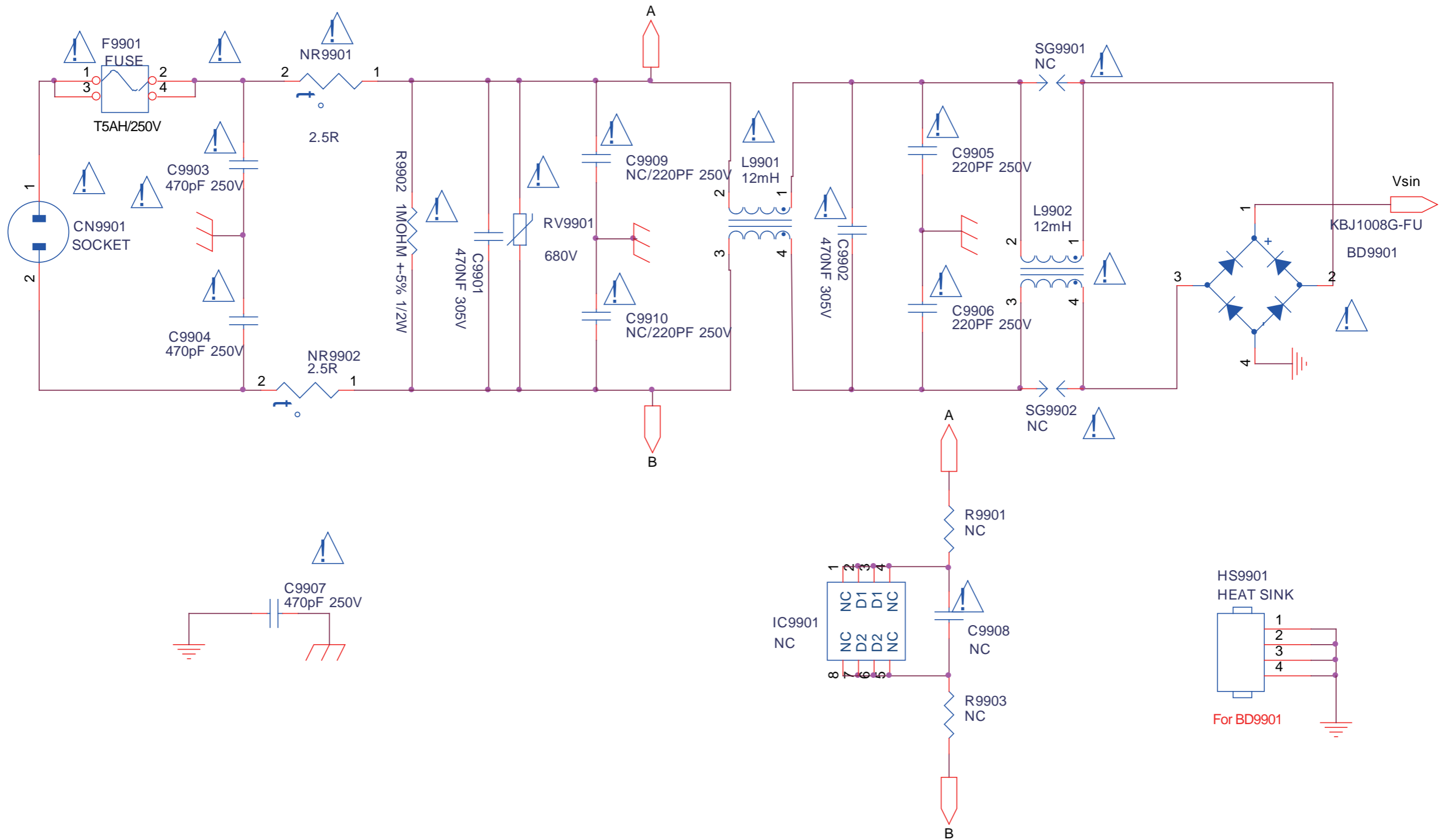

AC INPUT	715G6463	2014-01-16

A02 LED DRIVER

A02

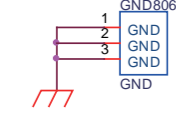
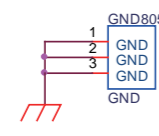
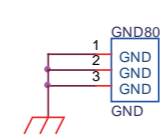
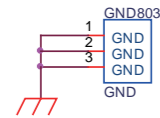
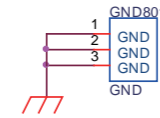
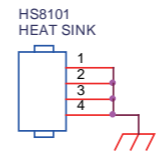
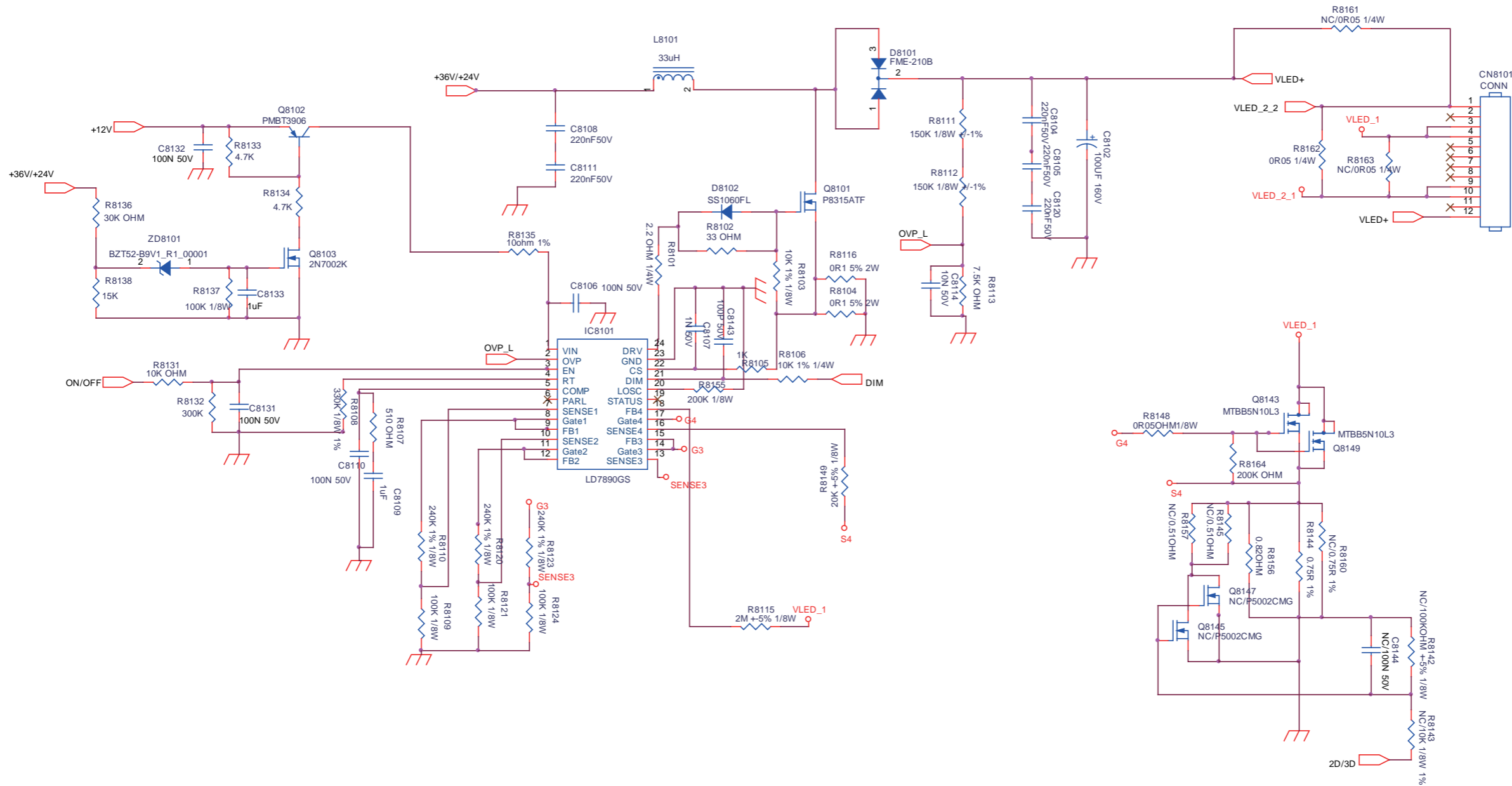

LED DRIVER	715G6463	6	2014-1-14
------------	----------	---	-----------

10-2-3 LLC 36V

A03

LLC 36V

A03

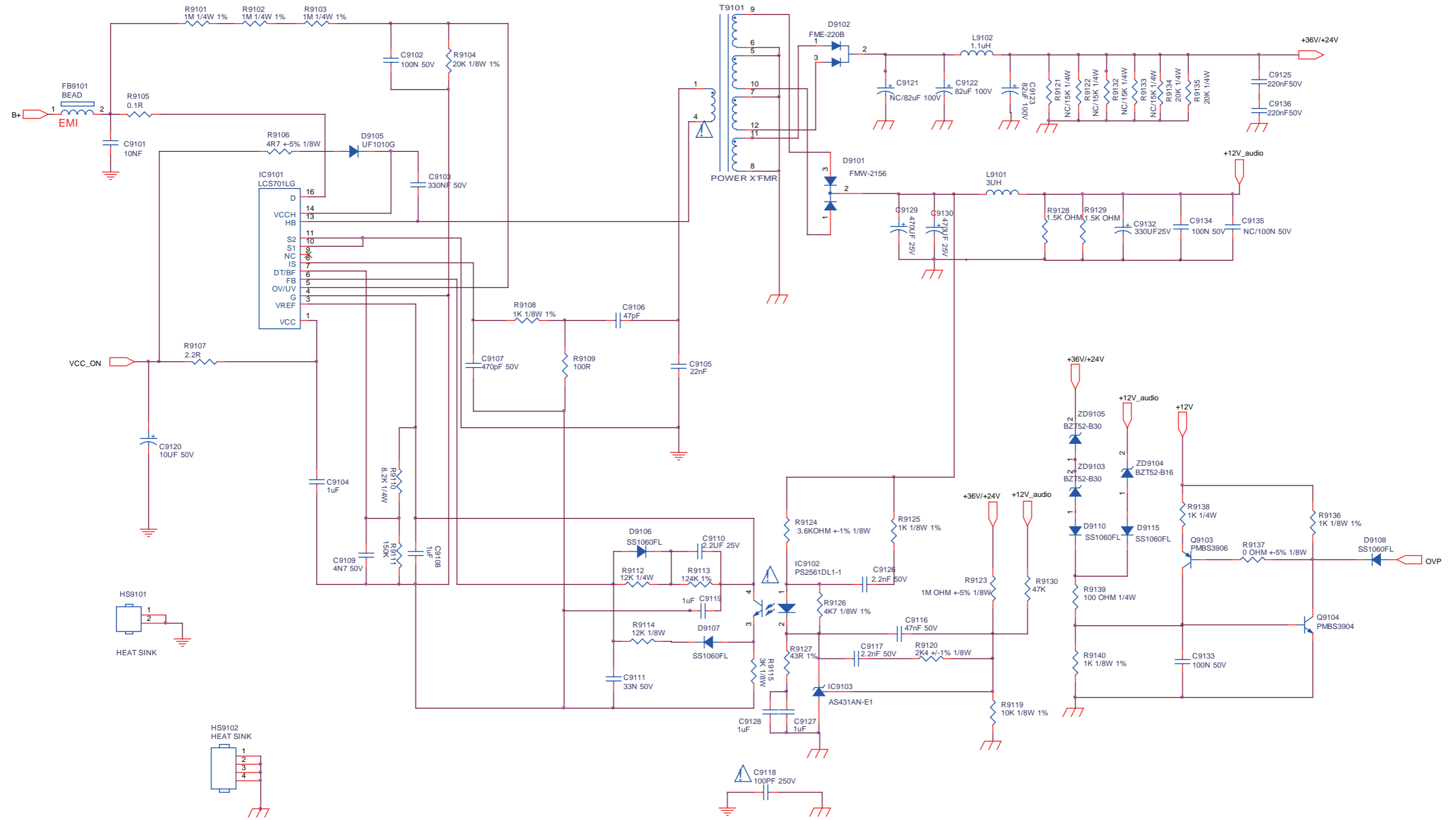

LLC 36V	715G6463	E	2014-1-14

10-2-4 MAIN POWER 12V

A04

MAIN POWER 12V

A04

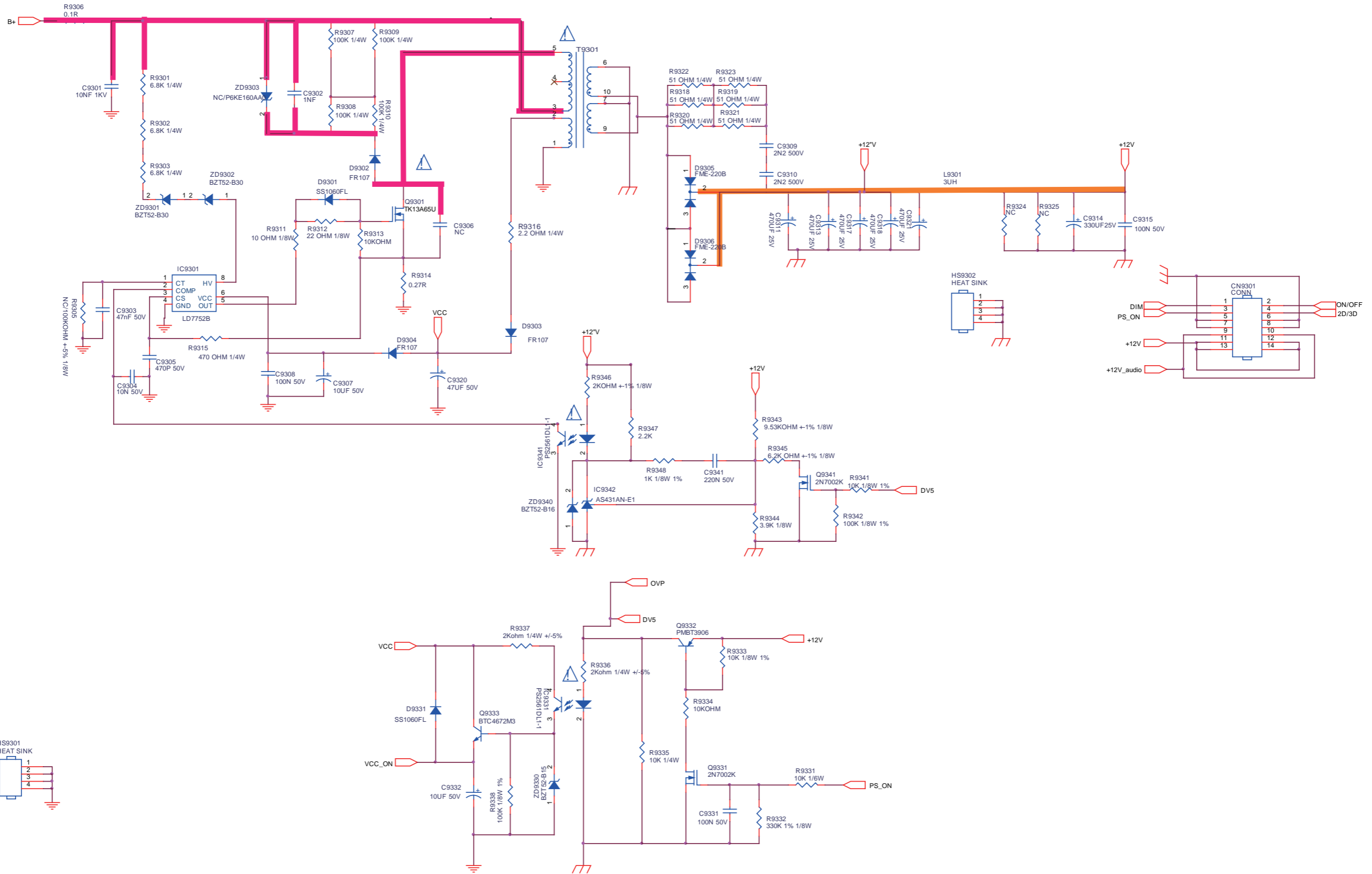

MAIN POWER 12V	715G6463	E	2014-1-14

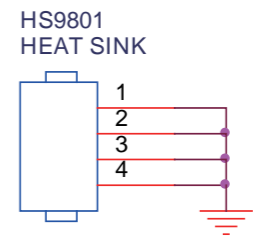
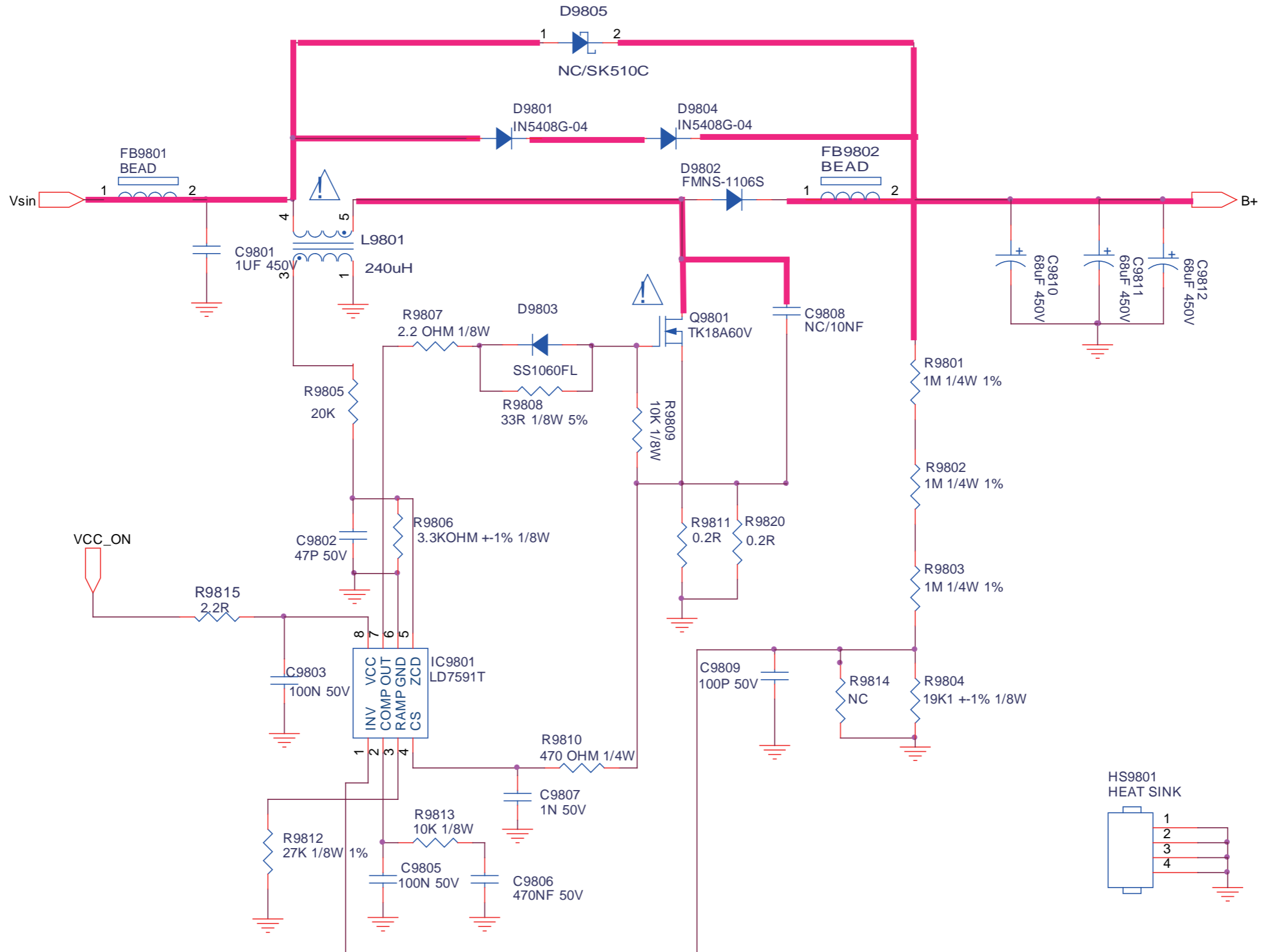

PFC	715G6463	2014-1-14

10-2-6 Power layout top

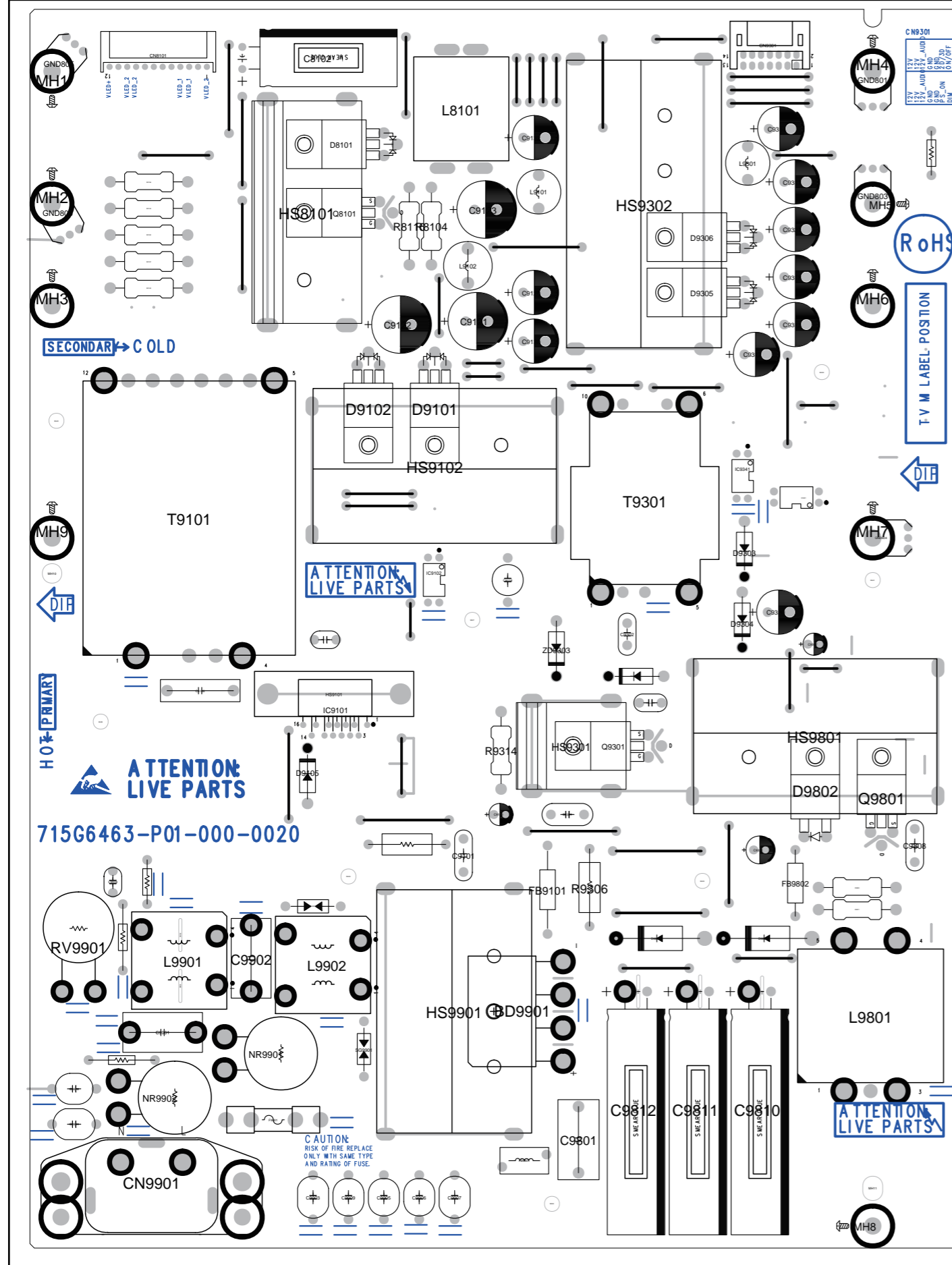

Power layout top	715G6463	e 2014-1-14

10-2-7 Power layout bottom

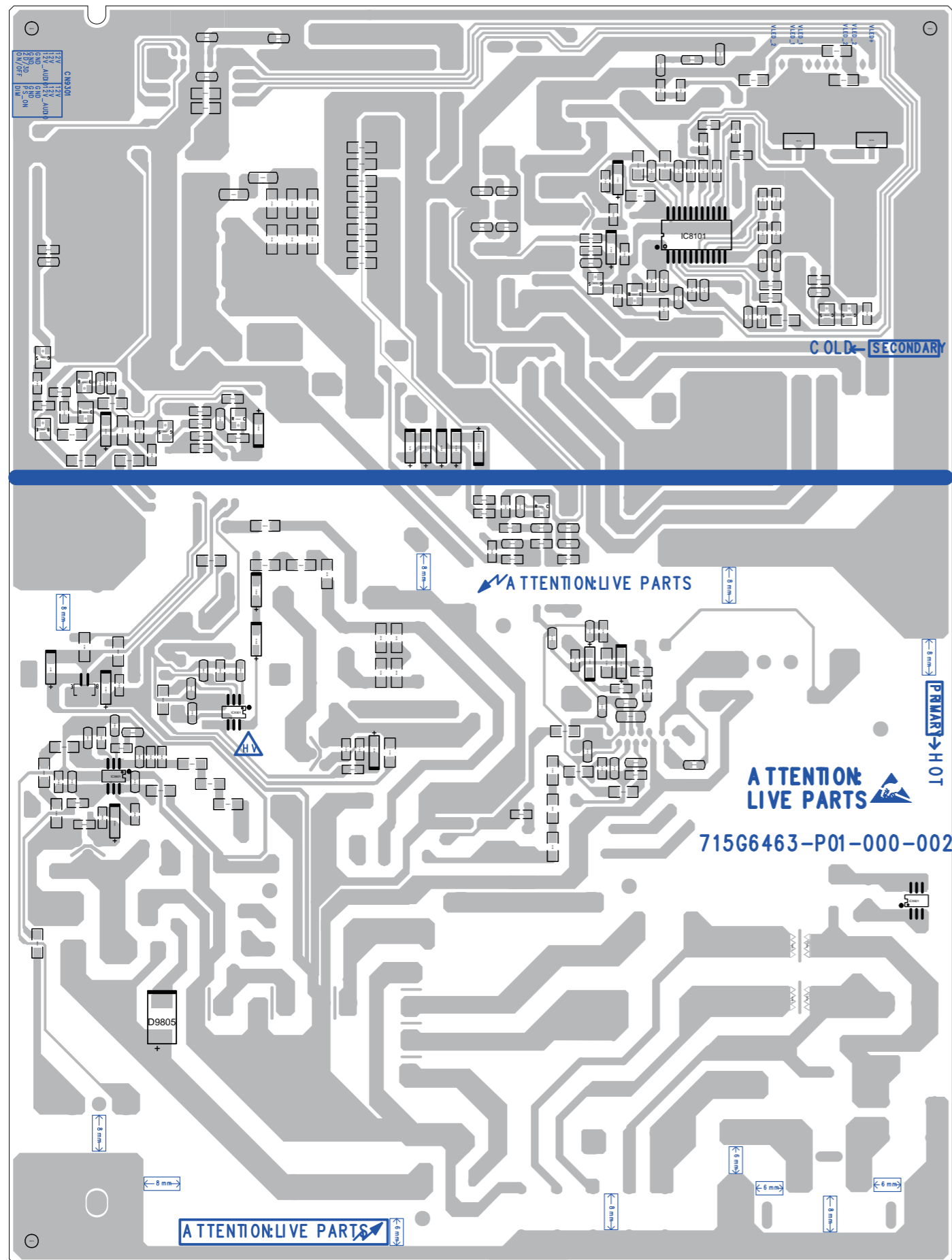

Power layout bottom	715G6463	1	2014-1-14